

Electric Maxidoor[®]

ENG

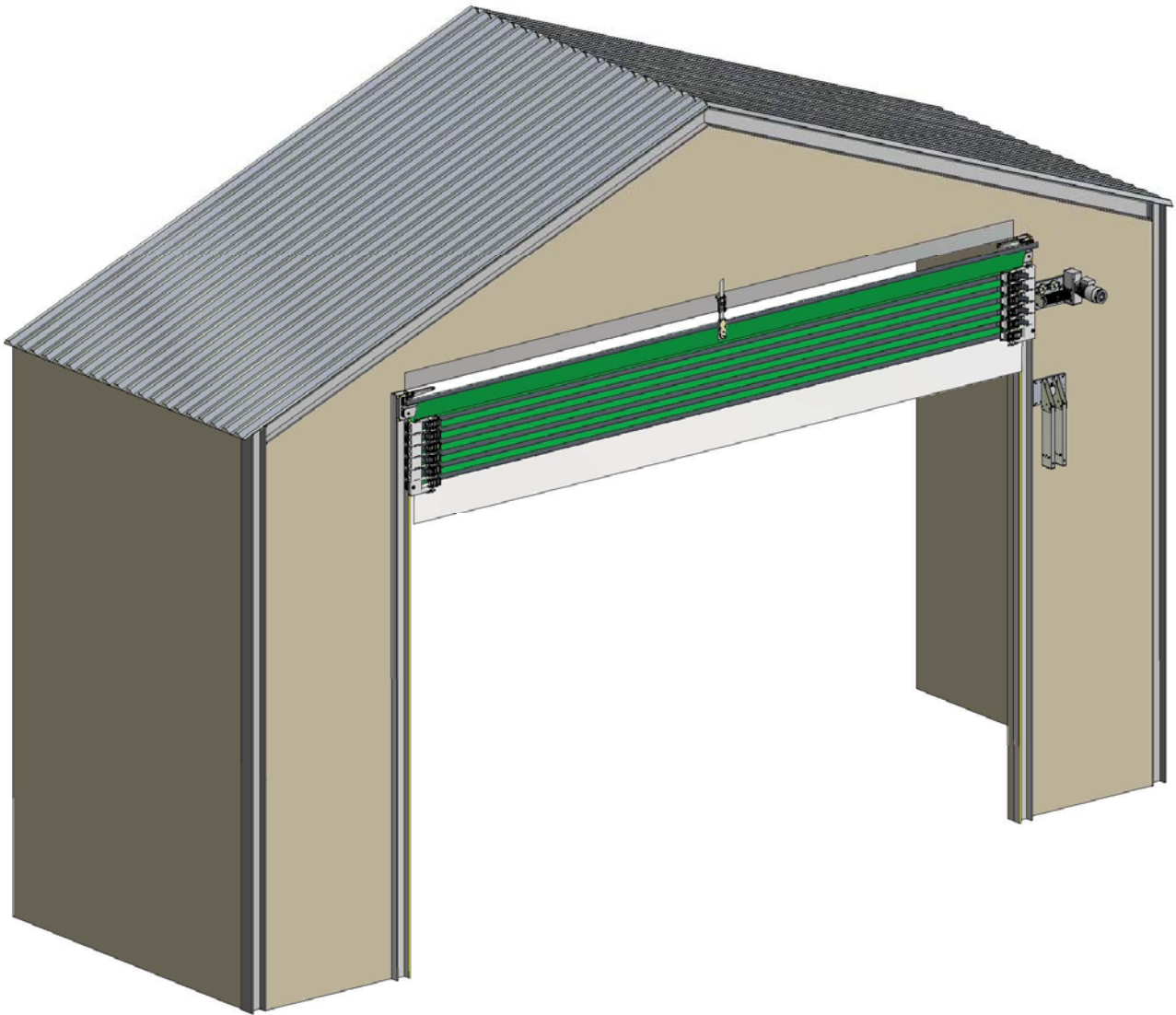

Installation Instructions



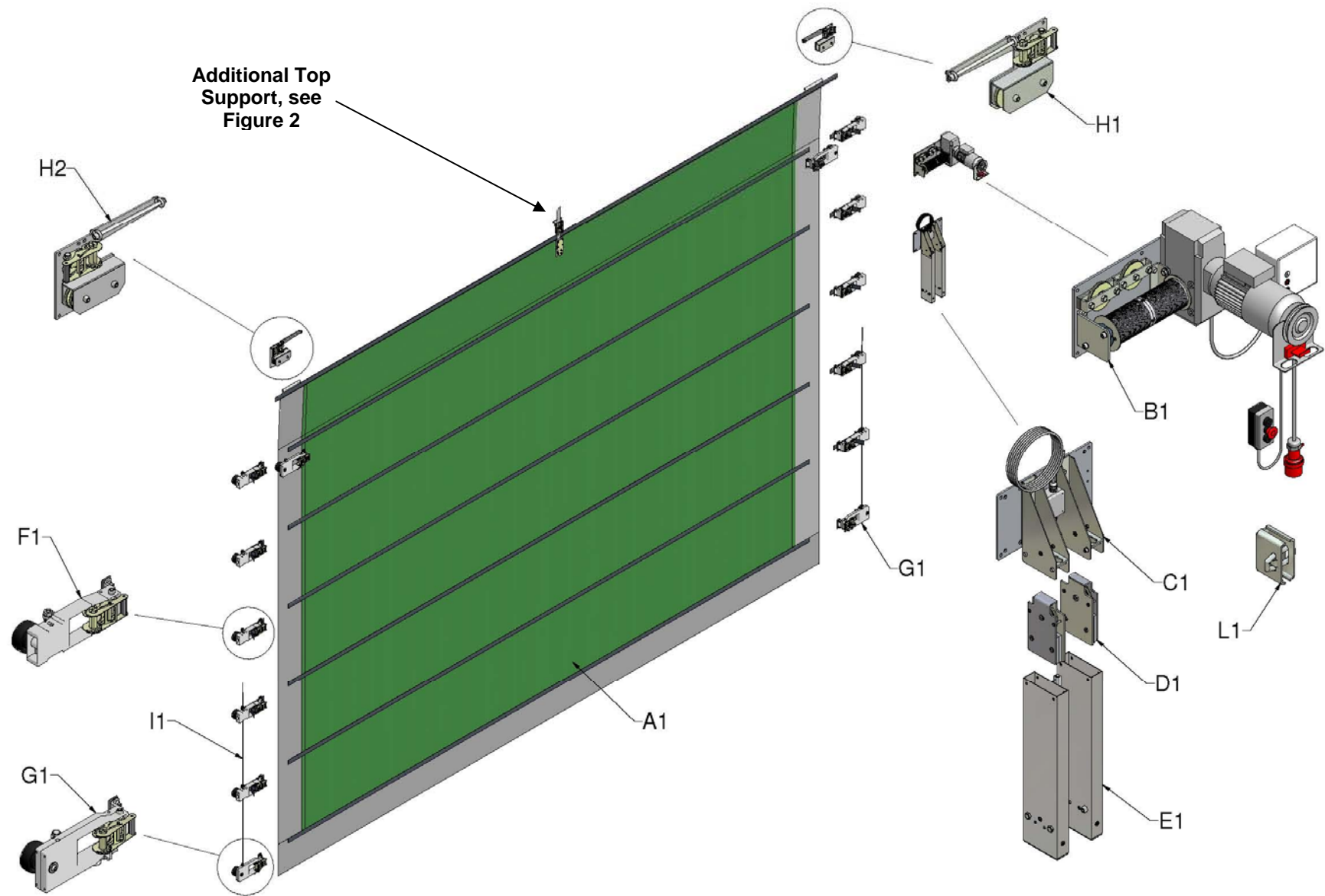

Figure 1

INTRODUCTION**Table 1: Parts List for Main Door**

FIGURE 1 REF:	QTY	DESCRIPTION
A1	1	Door Panel
B1	1	Electric Drive with Control Box, Power Lead, Manual Override Chain (Not Shown) and Three Push-Button Switch (3PB)
C1	1	Counterweight Mounting Plate
D1	2	Counterweights
E1	2	Counterweight Containment Boxes with Micro-Switches
F1	*	Intermediate Trolleys with 2no. PVC Pads & Fixing Bolts
G1	1	Right Lower Trolley with 2no. PVC Pads & Fixing Bolts
G2	1	Left Lower Trolley with 2no. PVC Pads & Fixing Bolts
H1	1	Right-Hand Top Plate Assembly
H2	1	Left-Hand Top Plate Assembly
I1	1	Reel 4mm Stainless Steel Cable (Not Shown)
I2	4	5mm Cable Grips to fix Cable to Lower Trolley (Not Shown)
J1	8	M8 x 30 Bolts to Secure Top Plate Assembly to Building (Not Shown)
K1	4	M10 x 50 Bolts to Secure Drive and Counterweight Mounting Plates to Brackets (Not Shown)
L1	1	Chain Keep
M1	2	M6 x 65 Bolts to Secure Chain Keep to Building (Not Shown)

* Quantity according to size of door

Additional Top Support

Doors over 10m wide are supplied with extra support(s) for the panel and lifting cable (Figure 2).

**Figure 2**

Table 2: Parts List for Additional Top Support

FIGURE 1 REF:	QTY FOR DOORS 10M -> 14.9M	QTY FOR DOORS 15M -> 20M	DESCRIPTION
SA1	1	2	50mm Ratchet
SB1	1	2	Ratchet Bracket
SC1	1	2	M12 x 90 Bolt
SD1	1	2	50mm x 4m Webbing
SE1	4	8	85 x 85mm Clamp Plates
SF1	1	2	Wire Support Assembly
SG1	1	2	Wire Support Protection Pad
SH1	4	8	12 x 20mm Spacer
SI1	4	8	M8 x 20 Bolt
SJ1	4	8	M8 x 50 Bolt
SK1	3	6	M8 x 40 Bolts to fix Ratchet Bracket (not shown)#

#Alternative M8 fastenings required if fixing onto wood or concrete.

Description

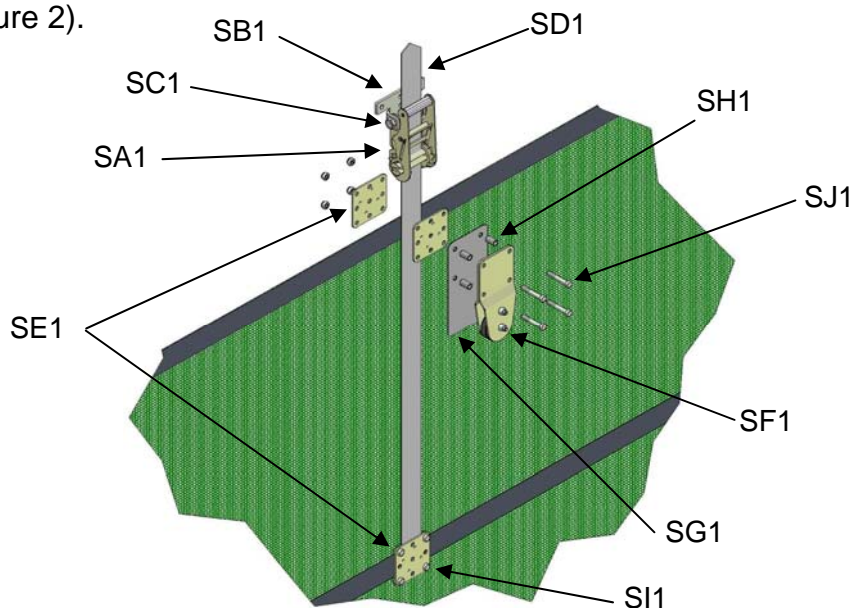
The Electric Maxidoor® is a power operated vertically moving folding door designed for building access requirements.

Optional Pelmet

If your door has been supplied with a Pelmet, see Appendix 1 for the Parts List and Installation Instructions. **Note the Pelmet needs to be installed before the door.**

Your Safety

The installation of the door panel is not recommended at excessive wind speeds as it could damage the curtain or injure the Installer.

Pre-Installation Check

For structural requirements refer to attached Maxidoor® Pre-Installation Instructions, these Installation Instructions assume all preliminary work has been completed

Right or Left Hand Drive

Your door will be supplied in accordance with the drive orientation specified when ordered. The images and text in these Instructions are based on a door with a right-hand drive, if you have ordered a left-hand drive then reverse the references. It is

possible to change drive orientation on-site, please contact Head Office for further information.

Installer Competence

The installer should be able to demonstrate the required level of competence via evidence of installing similar products or formal training. If competence cannot be proven then they should not be allowed to install the product.

ENG

Optional Adjacent doors with both drives on the extreme Left or Right

If this option has been ordered (Figure 3) then the door nearest the pair of drives is to be installed first using these instructions, with the exception of a small variation related to Section 3.4. The furthest door is to be installed second and has changes relevant to Section 2.1, 2.2, 3.3, 6.2 and 6.3. Details of all variations are detailed in Appendix 2.

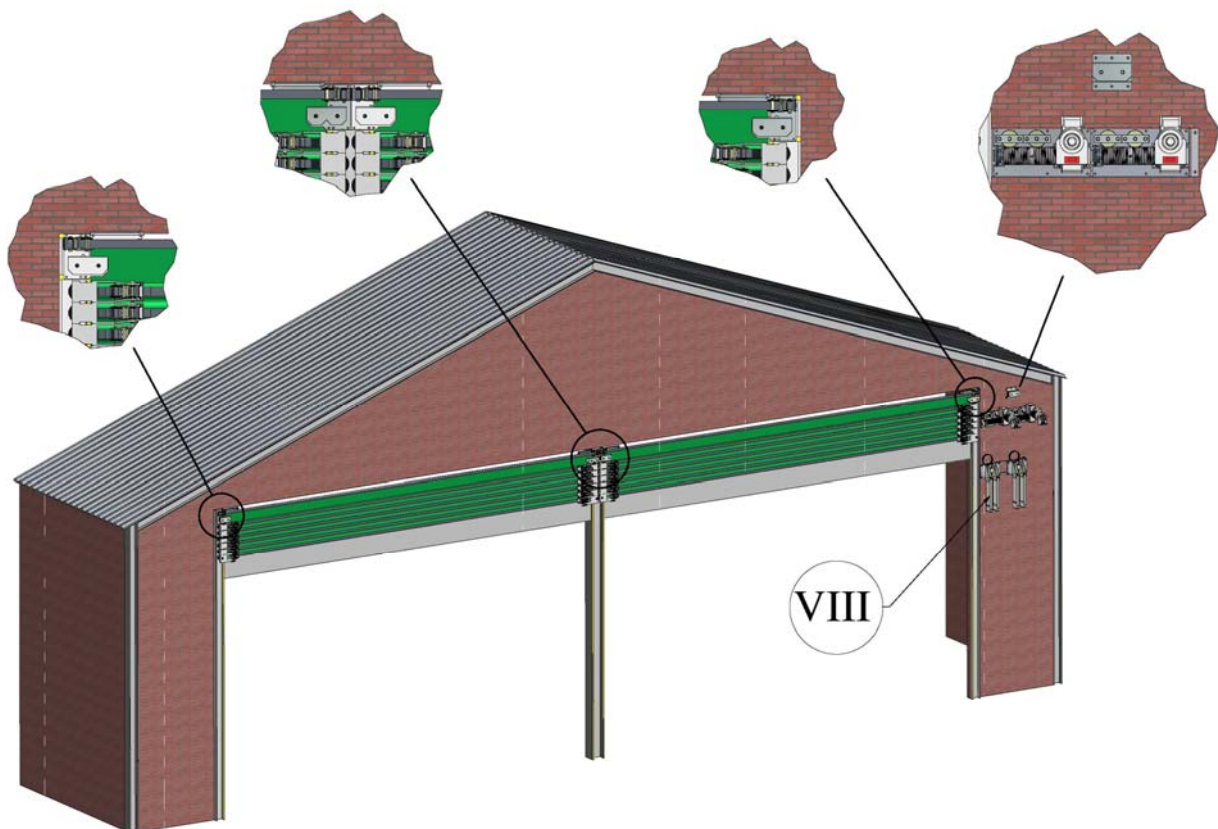

Figure 3

Electrics

Only allow qualified electricians to work on the electrical connections of the door. This document covers the key instructions with regards to bringing the Electric Drive into service. Read the additional information from the supplier of the Electrical Motor and Control Box for full installation instructions.

ENG

Items Required by Installer

Two personnel with a standard tool kit including:

- Allen key set: 3mm to 8mm
- 8mm socket or spanner for Cable Grips
- Electric drill
- Wire cutters and self adhesive PVC tape
- Sharp pair of scissors or knife
- Spirit level
- M10 Bolts for fixing Electric Drive and Counterweight Plates to Brackets up to 30mm thick are supplied.
- M6 Bolts for fixing Chain Keep to Brackets up to 30mm thick are supplied.
- Two packers for Trolleys, 150mm to 250mm tall (wood, brick etc.)
- Boom or Scissor lift to reach top of opening
- Power supply with LOCKABLE isolator within 1m of the Electric Drive.
Single Phase = 230V, 750W, 5.2 Amps
Three Phase = 400V, 1500W, 3.2 Amps
- Clips to fix Electric Wires to the Building

Key Instructions

CAUTION: Potentially hazardous situation: must be avoided otherwise injuries may result.



ATTENTION: Observe the given instructions otherwise the product or adjacent items may be damaged

NOTE: Helpful comments and information to assist in installation or use of your product

NOTE: Before starting the installation you must fully read these instructions (including the separate electrical details) to completely understand the procedure. Keep the instructions supplied for reference purposes.

NOTE: Colour versions of the installation instructions can be downloaded from our website:

www.galebreaker.com

ENG

INSTALLATION

1. Optional Pelmet: If supplied, the Pelmet needs to be installed at this stage before commencing on the door, see Appendix 1 for details

2. Installing Top Plates and Drive

2.1 Top Plate Assembly: Bolt the Top Plates (H1 and H2) to the pre-installed brackets on the tracking top with the eight M8 x 30 bolts supplied (Figure 4)

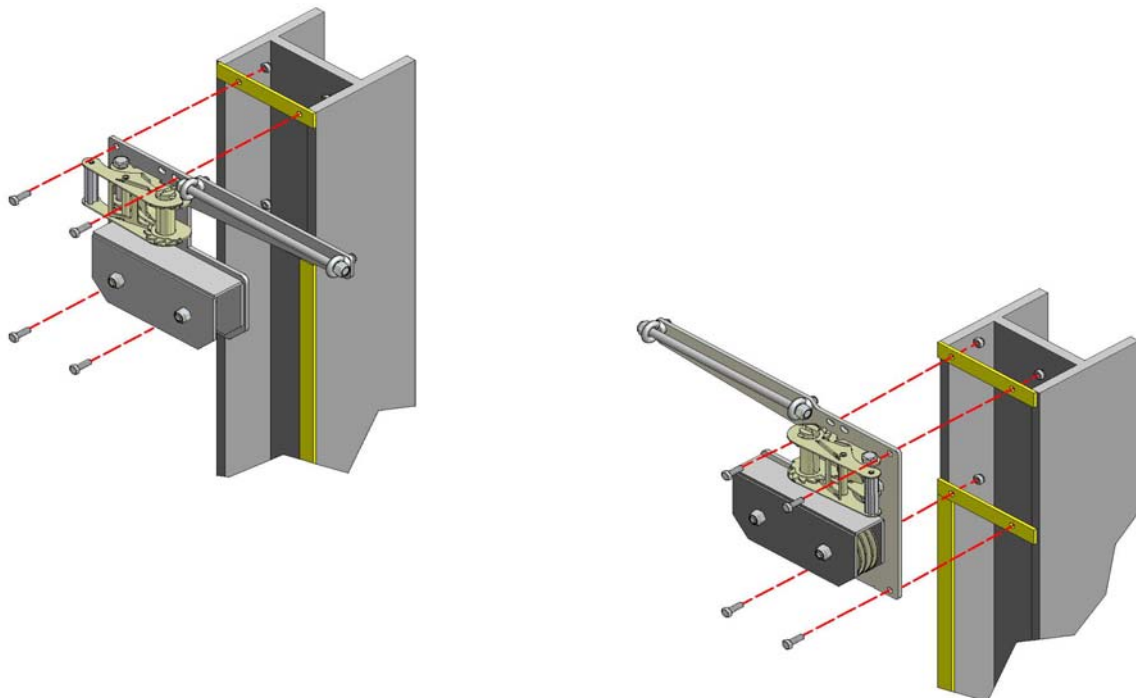

Figure 4

2.2 Bolt Electric Drive (B1) and Counterweight Plate (C1) onto pre-prepared brackets using the M10 Bolts supplied (Figure 5).



CAUTION: Ensure all fastenings detailed in section 2.1 through to 2.2 are secure and the fixing surface can withstand up to 350kg. Failure of these fixings could result in the door falling off the building, potentially injuring operators and bystanders

ENG

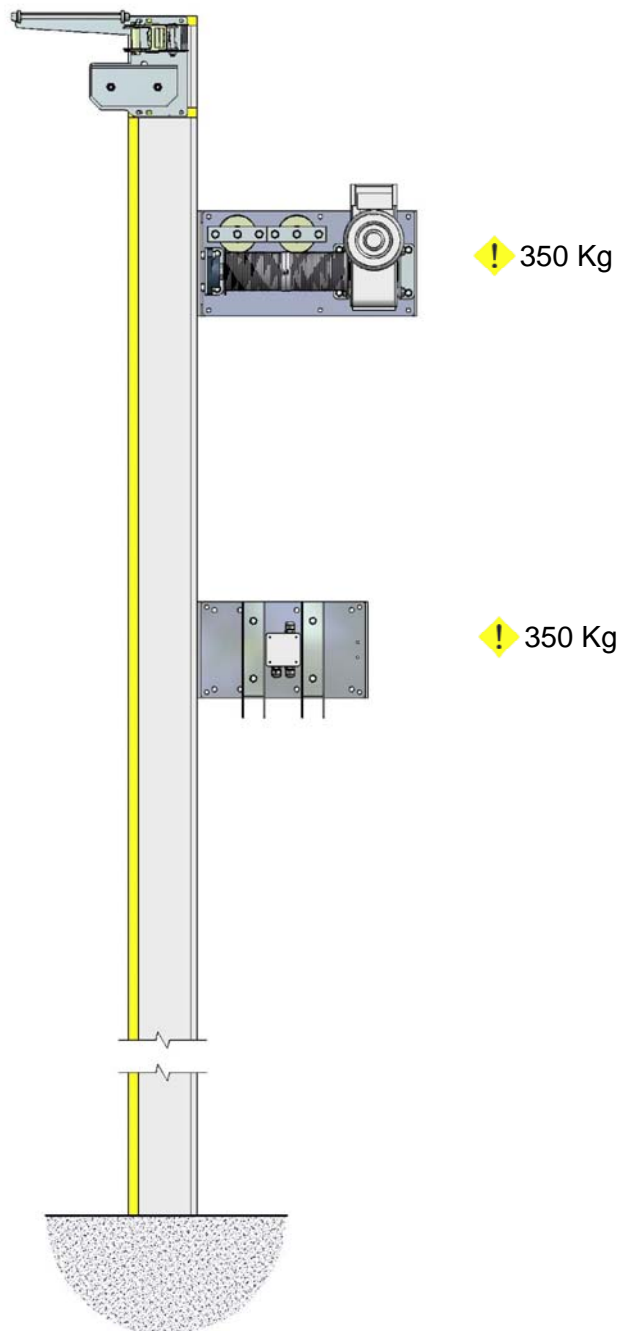

Figure 5

3. Installing Trolleys and Lifting Cable

3.1. Place packer (wood, brick etc.), 150mm to 250mm tall at the base of the tracking. Locate Trolleys onto Tracking with the wheel behind the retaining lip, Figure 6. Ensure the Lower Trolleys (G1 and G2) go on the bottom with the eyebolt facing down and that there are an equal number of Intermediate Trolleys (F1), on either side. In total there should be two trolleys for each webbing strap, excluding the upper one (which is fixed to the Top Plates).

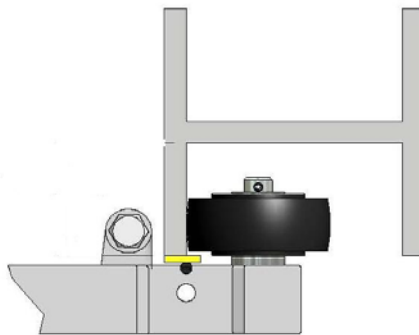

Figure 6

3.2 Preparation for inserting lifting cable:

- Ensure the adjusting eyebolt on the Lower Trolley is centrally positioned Figure 7.1
- To prevent cable fraying, wrap PVC tape around cable before cutting

3.3 Thread cables (I1) as indicated in Figures 7 and 8. Starting at the Lower Trolley wrap the cable around the adjusting eyebolt and secure with two 5mm Cable Grips (supplied), ensure the bridge section of the grip is against the cable under tension (Figure 9).



CAUTION: Ensure the Cable Grips are correctly used and fully tightened. Failure could result in the door falling off the building, potentially injuring operators and bystanders

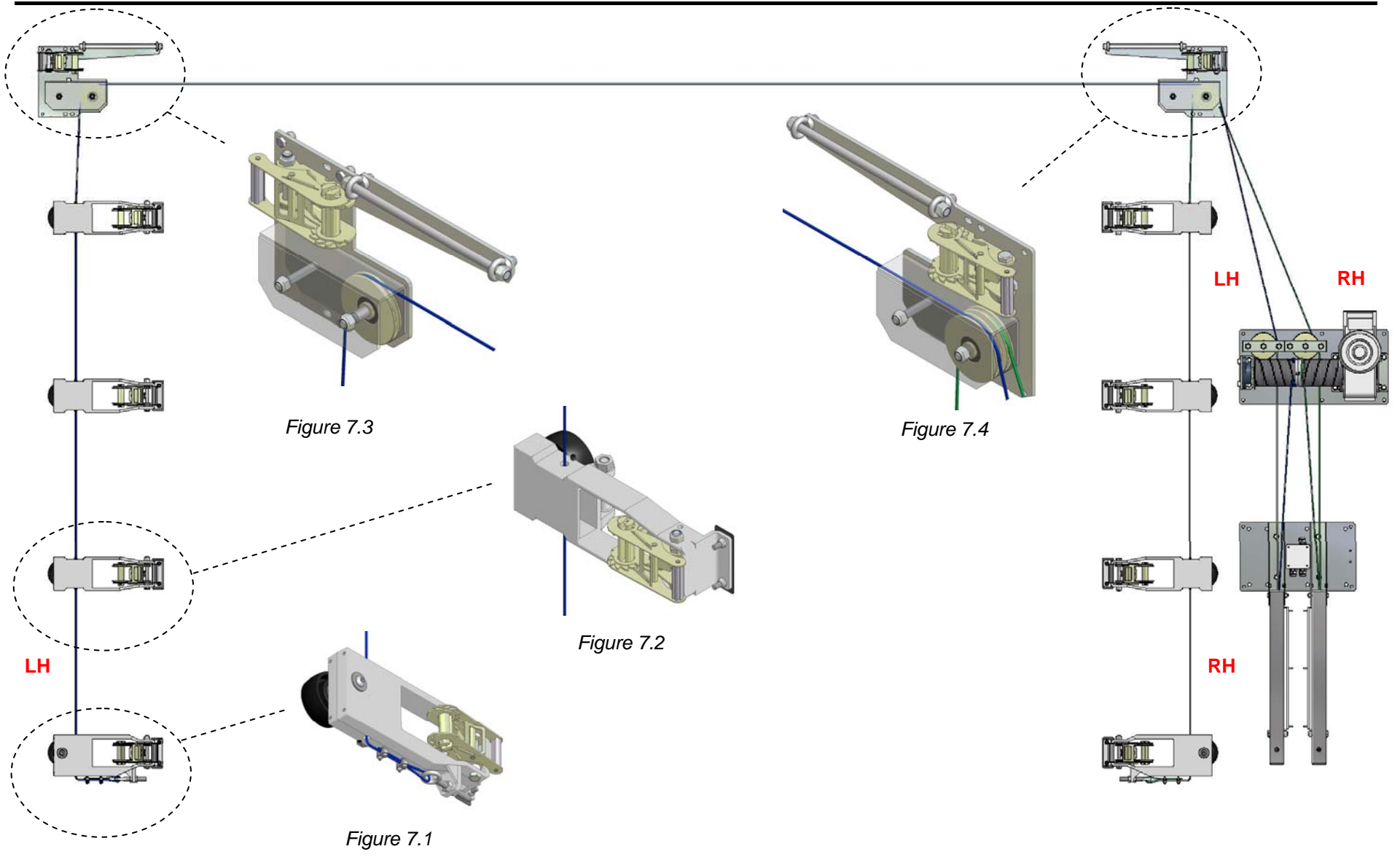

Figure 7

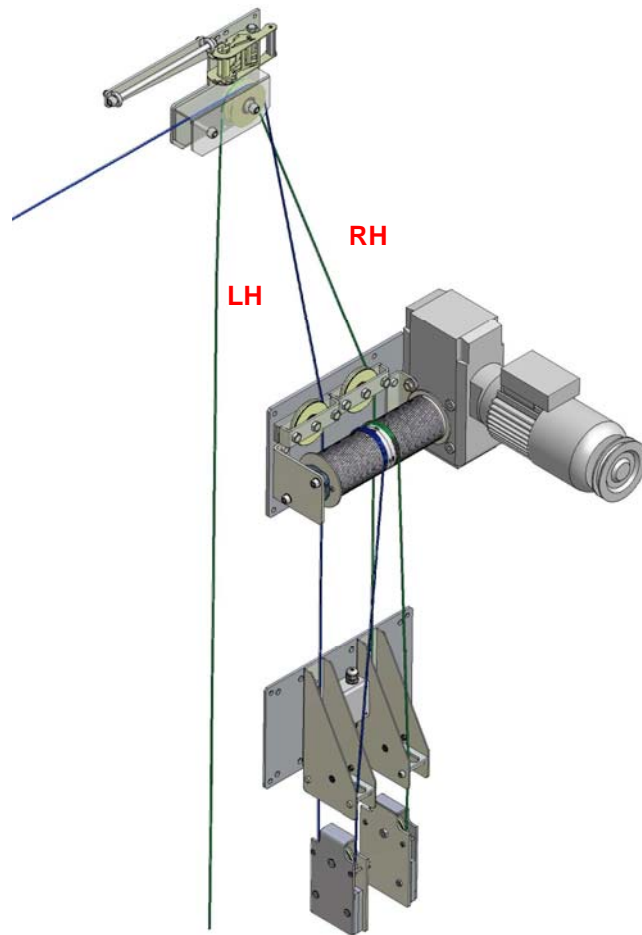

Figure 8

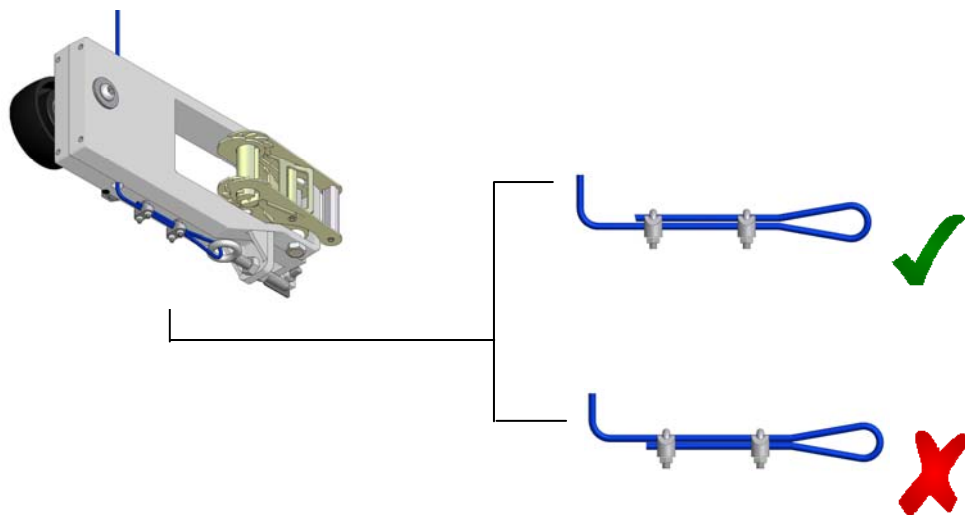

Figure 9

3.4 Doors up to 10m wide:

Thread Cables through hole in Intermediate Trolleys (Figure 7.2), around the pair of Top Plates (Figures 7.3 and 7.4). Pay particular attention to the Cable routing on the right-hand Top Plate (Figure 7.4). Referring to Figure 8, continue Cables around 100mm pulleys on the Electric Drive down through Counterweight Plate, around Counterweights (D1) and back up to the Drive. Ensure the Left and Right Cables are positioned as indicated.

Doors over 10m wide with Additional Top Support(s):

Follow the details above, but include the Wire Support Assembly(s) SF1 when passing the Cable between the pair of Top Plates (Figure 10).

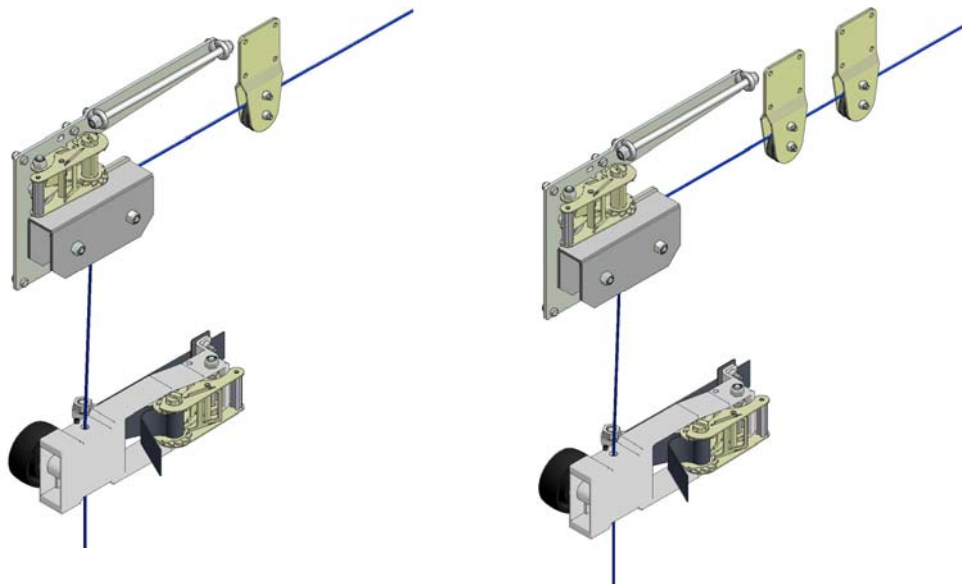

Figure 10

3.5 Attaching Lifting Cable to the Electric Drive: For safe operation of the door, the lifting cable must pass around the grooved drum a minimum of three times, to achieve this pass the cable 950mm beyond the drums centre-line and cut to length. Secure end of cable into the 6mm hole located towards the centre of the drum and secure in place with the socket set screws.

3.6 Repeat process for the other Cable, when both have been installed operate the Electric Drive using the Manual Override Chain. To use the Chain Override, first release the Motor brake before lifting the Hand Chain over the Chain-Wheel as shown in Figure 11. Ensure:

- The Cables feed onto the front of the drum (Figures 8 and 12)
- The Cables follow the groove in the drum

Continue to operate the Drive until the two stacks of Trolleys begin to lift, check they are level and adjust as necessary. Small adjustment can be achieved via the Lower Trolley adjusting eyebolt.



CAUTION: Ensure there are a minimum of three wraps of Lifting Cable around the drum when the door is fully lowered. Failure could result in the door falling off the building, potentially injuring operators and bystanders

Normal Electric Drive

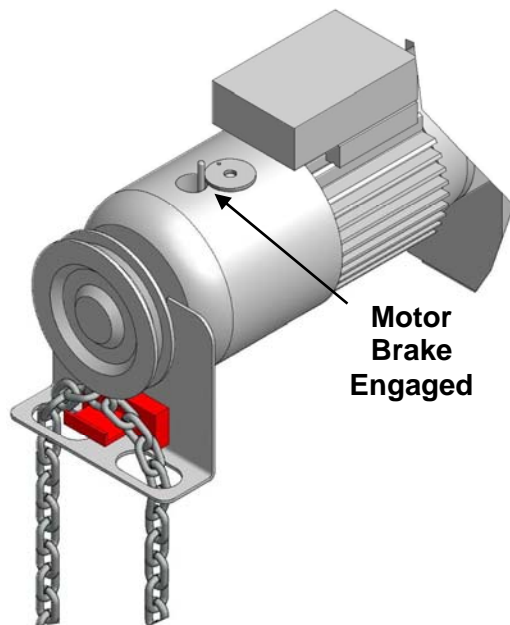

Manual Override

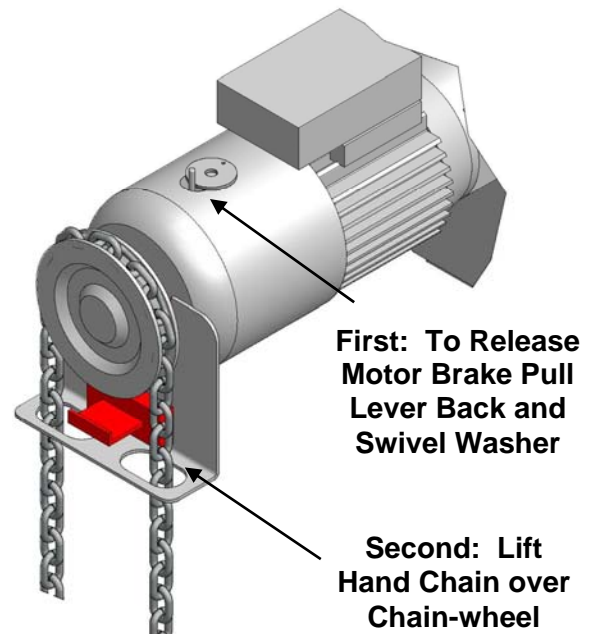
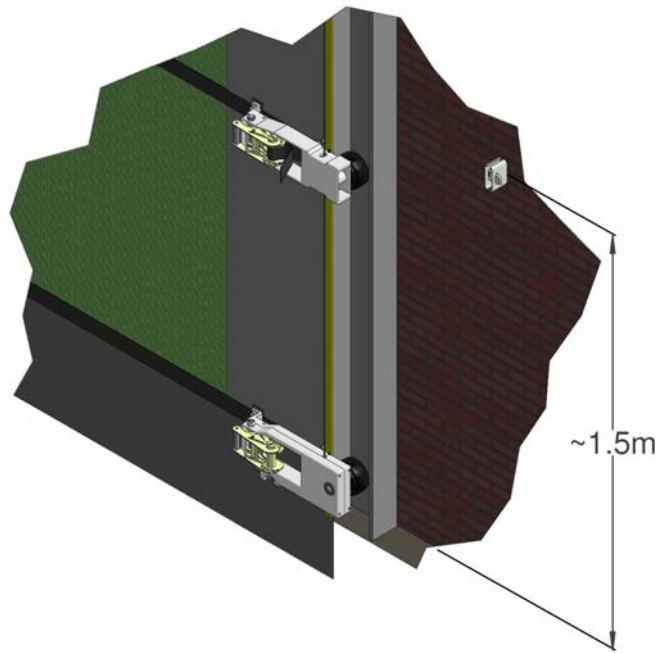

Figure 11a



ENG

Figure 11b

Install the chain keep to the building, the height of the chain keep depends upon your installation (Figure 11b), but is typically 1.5m high.

3.7 Fit Counterweight Containment Boxes (E1) onto Counterweight Plate (C1) using the M8 x 70 Bolts that are placed in the Counterweight Plate fixing holes, see Figure 12.

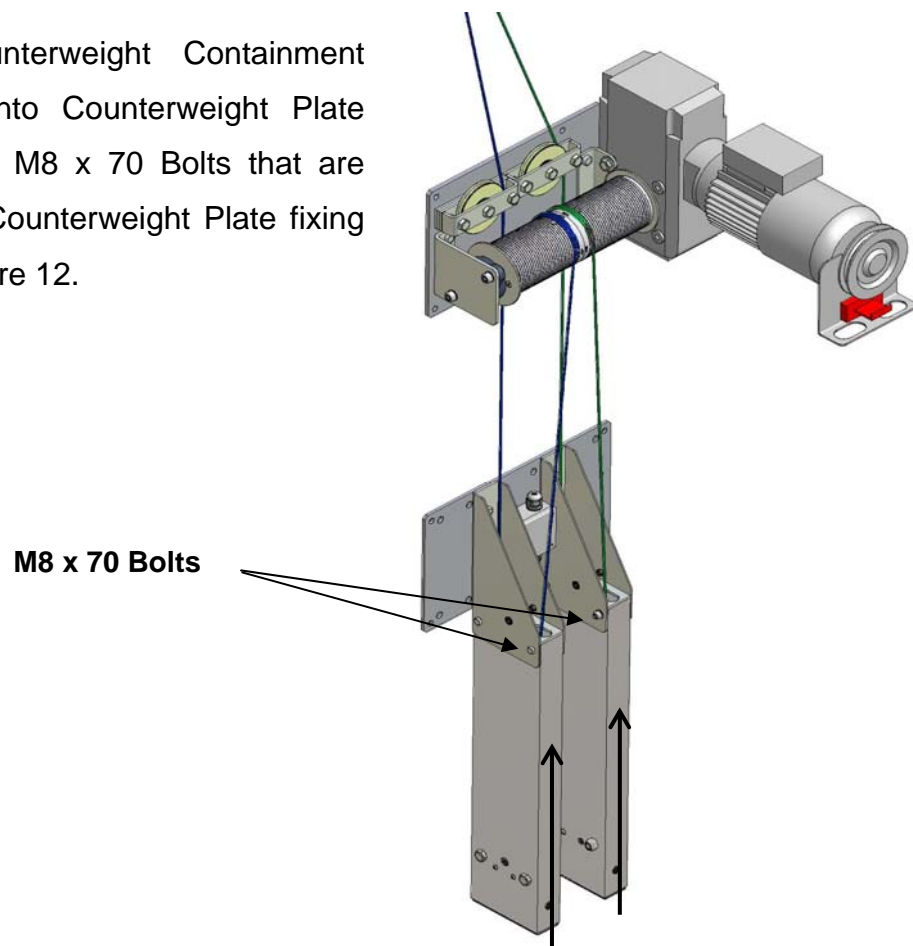

Figure 12

4. Commissioning Electric Drive

4.1 Fix Control Box to building and connect power lead to isolator: The Control Box is designed to be at the level of the Electric Drive and **must be fitted internally** away from direct rainfall. Ensure the glands face down and the wires form a drip loop beneath the Control Box. Clip wires to building.

4.2 Fix Three Push-Button Switch (3PB) to building at low level, which can be installed either internally or externally. Ensure the glands face down and the wires form a drip loop beneath the Switch. Clip wires to building.



CAUTION: For safety, the switch must be positioned in sight of the door.



ATTENTION: For points 4.3 through to 4.7 read this information in conjunction with the full installation instructions from the supplier of the Electrical Motor and Control Box.

4.3 Mains Connection: Ensure the link wire in Terminal Block X3 is in the correct location to match the type of mains supply



CAUTION: When the lid of the Control Box is removed there are High Voltage contacts exposed.

4.4 Checking Direction of Operating Buttons:

Press the Open Button inside the Control Box (located in the bottom left-hand corner for single phase controller or top centre '+' button for three phase controller), if the stack of trolleys begin to lift then proceed to next point. If the direction is opposite then follow the details as outlined in Table 3. All information relates to the power supply entering the Control Box.

Table 3: Changing Direction of Operating Buttons

TYPE	INSTRUCTIONS
230V Single Phase	Swap Location of wires W1 and V1
400V Three Phase	Swap Location of wires L1 and L2

4.5 Checking Direction of the 3PB: Press the 3PB to check it is operating the same as the Control Box.

4.6 Checking Direction of Open and Closed Limit Switches: Move the Green and White Cam on the Electric Drive so they are clear of the Limit Switches. Press the Open Button to lift the stack of trolleys 1m, note the direction of the Cam. Adjust the Cams so that they are just before the Open and Closed limit switches, (the Green Cam is for the Open Direction and the White Cam is for the Closed Direction). Press the Open and Close Button to check that the limit switches are wired on the correct side, if the Electric Drive does not stop when the limits are depressed by the Cams then swap wires 6

and 7 for single phase or wires 2 and 4 on Terminal Block X15 for three phase and repeat the test.

4.7 Wiring in the Counterweight Micro Switches: Following Figure 13 connect the Counterweight Containment Box (E1) Micro-Switches in series with the Motor Closed Limits. Route of wire to pass through the Junction Box located on the Counterweight Plate (C1) and then into Closed Limit of the Control Box. Spare terminal strip is located in the Junction Box on the Counterweight Plate.

ENG

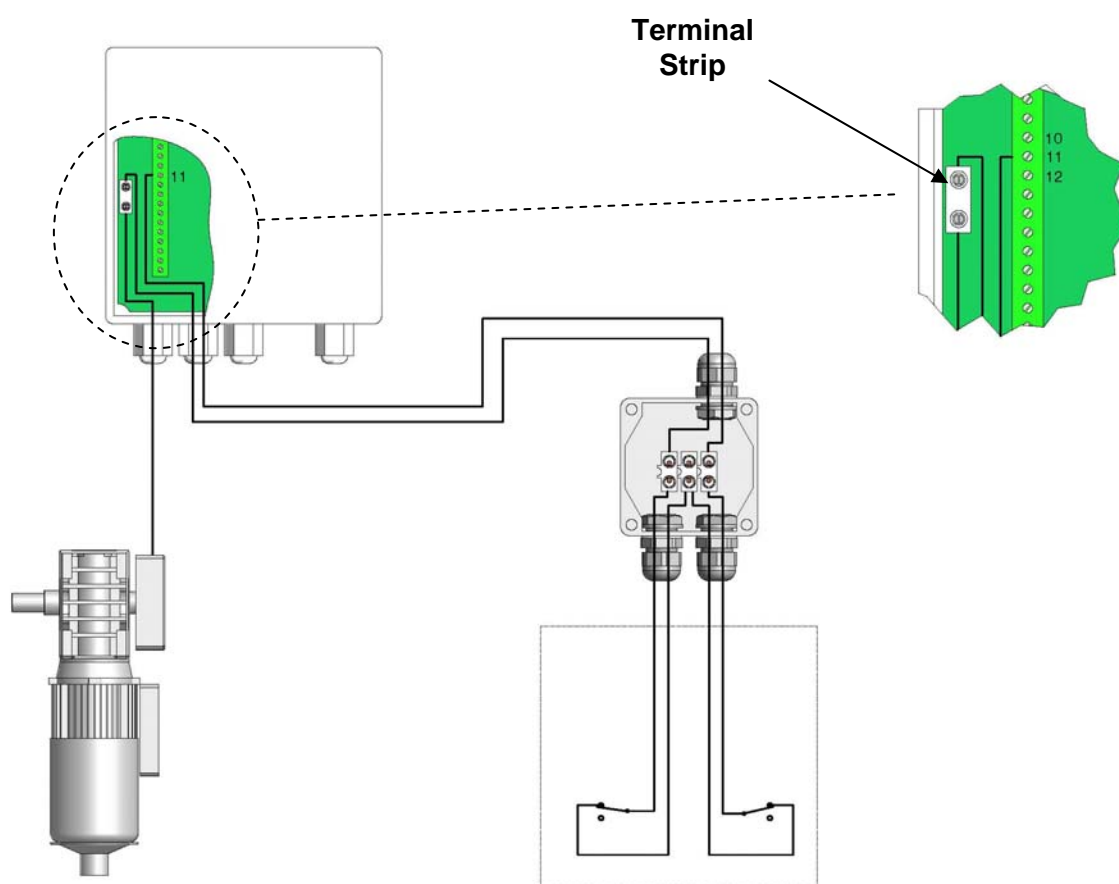
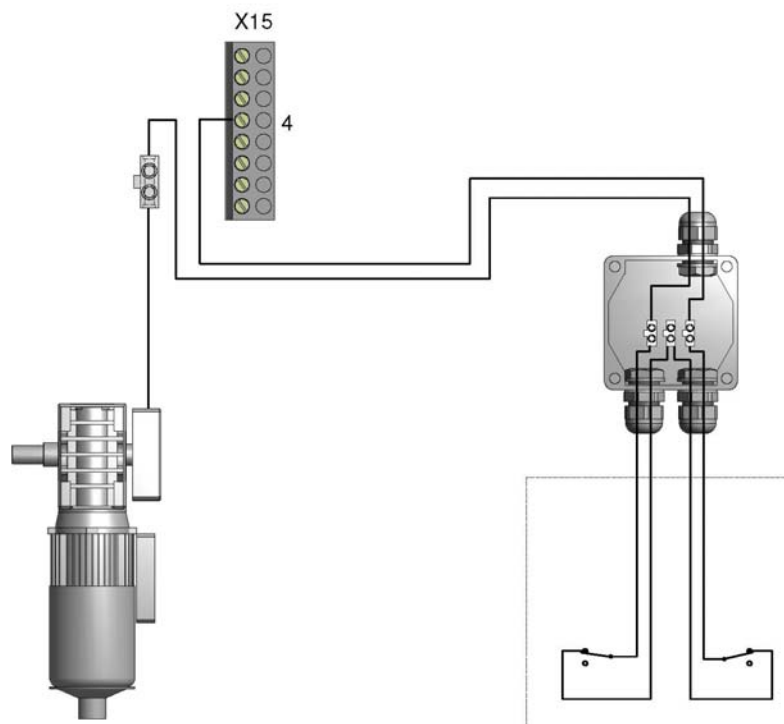

Figure 13a, Single Phase



ENG

Figure 13b, Three Phase

5. Installing door panel

5.1 Orientation of door panel (A1): The webbing straps face towards the outside and the top is identified by the two 400mm long x 40mm pockets located at either end of the panel (Figure 14).

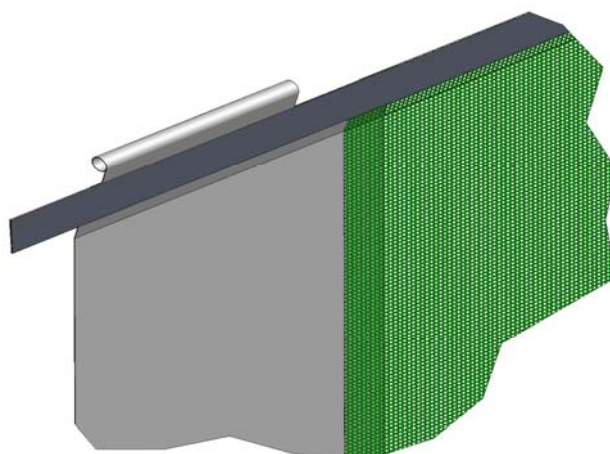

Figure 14

5.2 Lay the panel across the opening in preparation to fasten the webbing straps to each Trolley. Working up from the bottom Trolley first, pass the webbing strap around the nylon bushes on the Trolley pillar and back towards ratchet tensioner. When the panel edge is approximately 150mm to 250mm from Trolley pillar feed webbing strap through slot in ratchet barrel and operate the handle (Figure 15). At this point do not let the Panel touch the pillar. With the exception of the upper strap (which is fixed to the Top Plates) repeat for all webbing straps, ensuring the Panel is central and applying equal tensioning throughout.



ATTENTION: To ensure the ratchet functions correctly there must be a minimum of 150mm webbing around the ratchet barrel for secure & permanent tensioning of the panel.



ATTENTION: Overloading the ratchet barrel with webbing will restrict the tension you can apply to the panel due to an increase in friction and a decrease in leverage. To free surplus webbing pull ratchet release catch on handle and open 180 degrees until ratchet body is flat and pull on webbing strap.

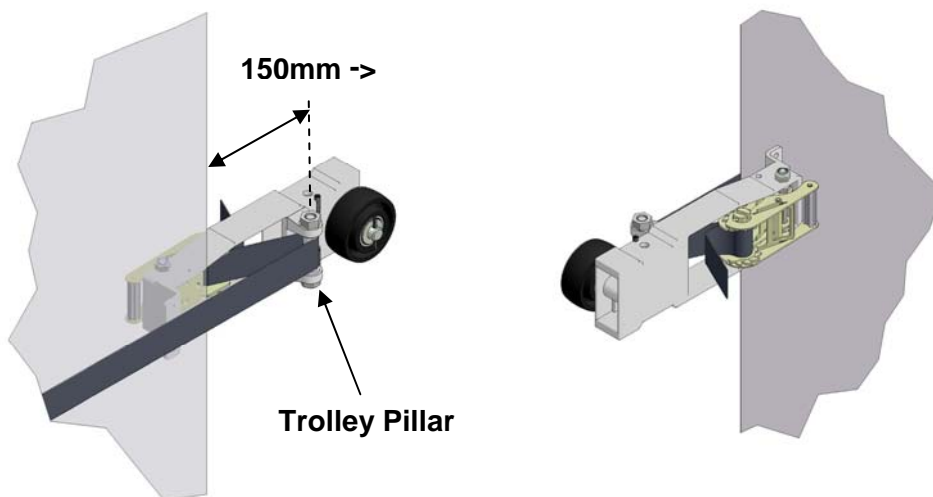

Figure 15

5.3 Operate the Electric Drive to fully lift the Panel (the Green Cam may have to be adjusted to achieve this). Following the principles detailed in section 5.2 fasten upper webbing strap into Ratchets on Top Plates and

tension (Figure 16). Ensuring the Panel is central; **fully tension** the ratchets by hand until it is impossible to operate further. If the Panel material is being drawn into Ratchet, Section 5.4 details how to trim the fabric, once the adjustments have been made continue tensioning.

Feed the M12 x 300 threaded bar on the Top Plates though the 40mm pocket (Figure 16), the pocket may have to be trimmed to fit.



ATTENTION: Tension Ratchets fully, lack of tension will cause damage to the door Panel. Tension by hand only, use of levers could damage the Ratchets.

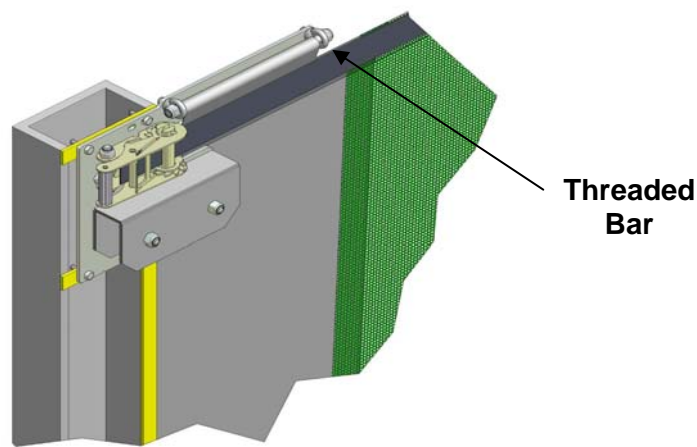

Figure 16

5.4 The Panel has been manufactured to suit the opening, however if trimming is required use scissors / knife to remove the fabric either side of the webbing strap, ensuring all corners have a radius (Figure 17). Always remove surplus fabric, do not just cut either side of the webbing which allows a loose flap to be generated. **Do not remove the fabric off the back of the webbing.** We recommend a cautious approach to trimming as final tensioning and adjustment is completed in section 5.5.

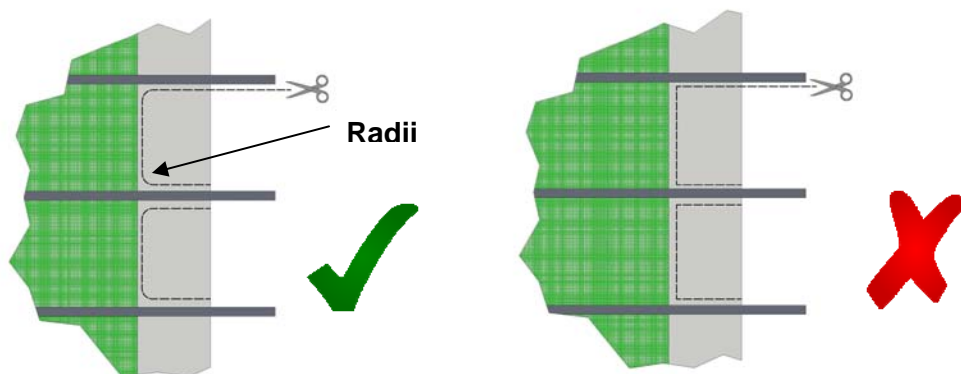
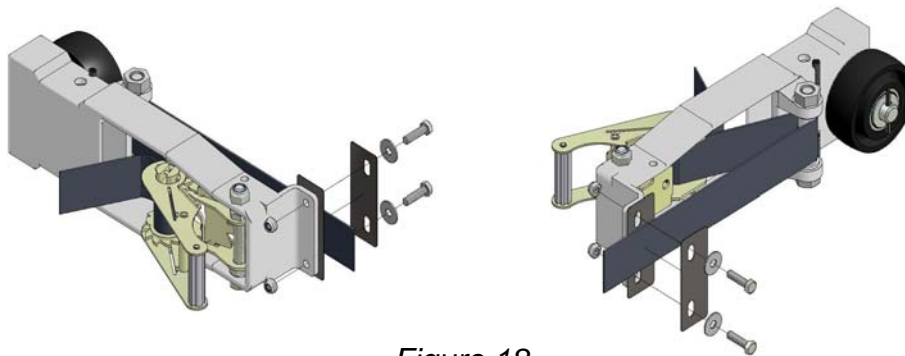

Figure 17

5.5 Using the Electric Drive fully lower the Panel (the Black Cam may have to be adjusted to achieve this). Revisit each trolley and whilst ensuring the system remains centralised operate the Ratchets to remove any wrinkles or creases, apply further tension by hand until it is impossible to operate the Ratchets. Complete final trimming of the Panel as necessary.

ENG

5.6 Bolt each Trolley back to the screen as shown in Figure 18 (image has fabric removed for clarity) using the M8 x 30 Bolts supplied. To allow the Bolt to pass through the Panel cut a slot 15mm to 20mm long in the Fabric. Note the webbing strap is placed between the two PVC Pads.

*Figure 18*

6. Doors over 10m: Additional Top Support(s)

6.1 Decide on the position of the top support, to minimise screen sag we recommend it is positioned as indicated in Figure 19a or 19b

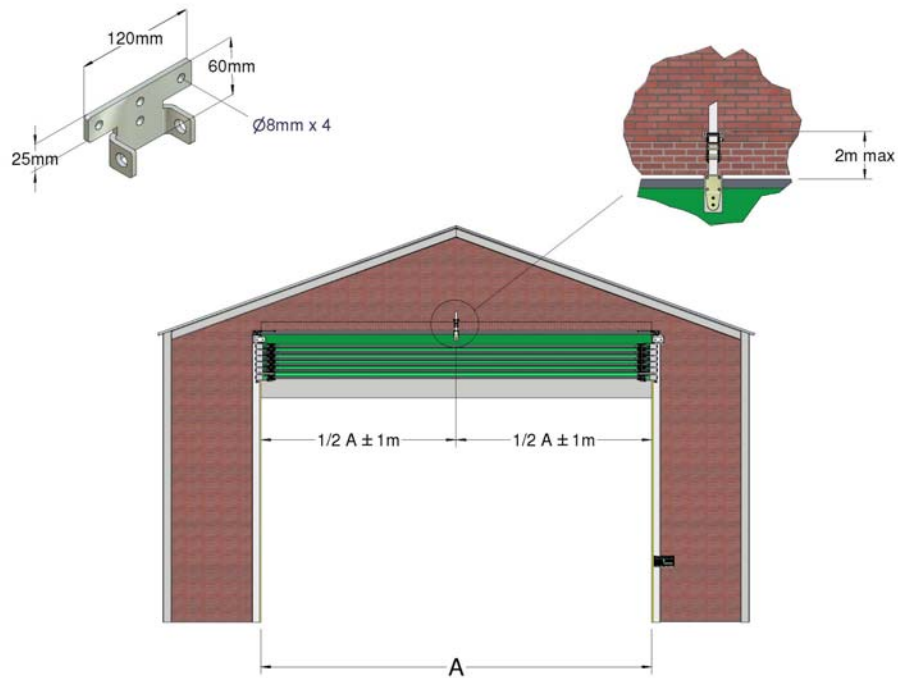

Figure 19a: Door 10m to 14.9m

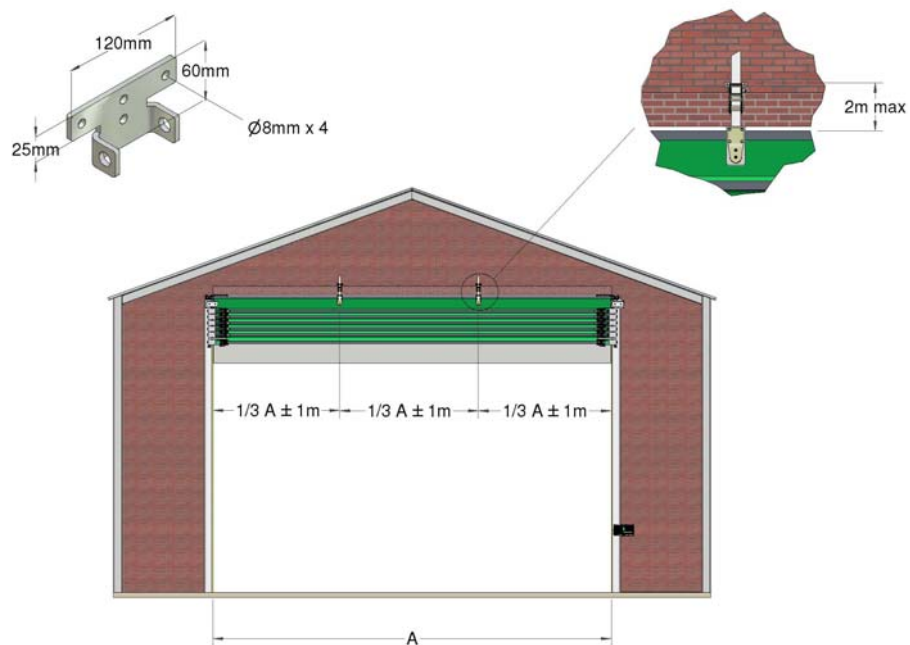

Figure 19b: Door 15m to 20m

6.2 Fix the Ratchet (SA1) to the Ratchet Bracket (SB1) with the M12 x 90mm bolt (SC1) provided. The standard fitting of the ratchet bracket is depicted in Figure 20, but it can be reversed if vertical mounting space is limited. Fit assembly to the building with three fixings, minimum size 8mm.

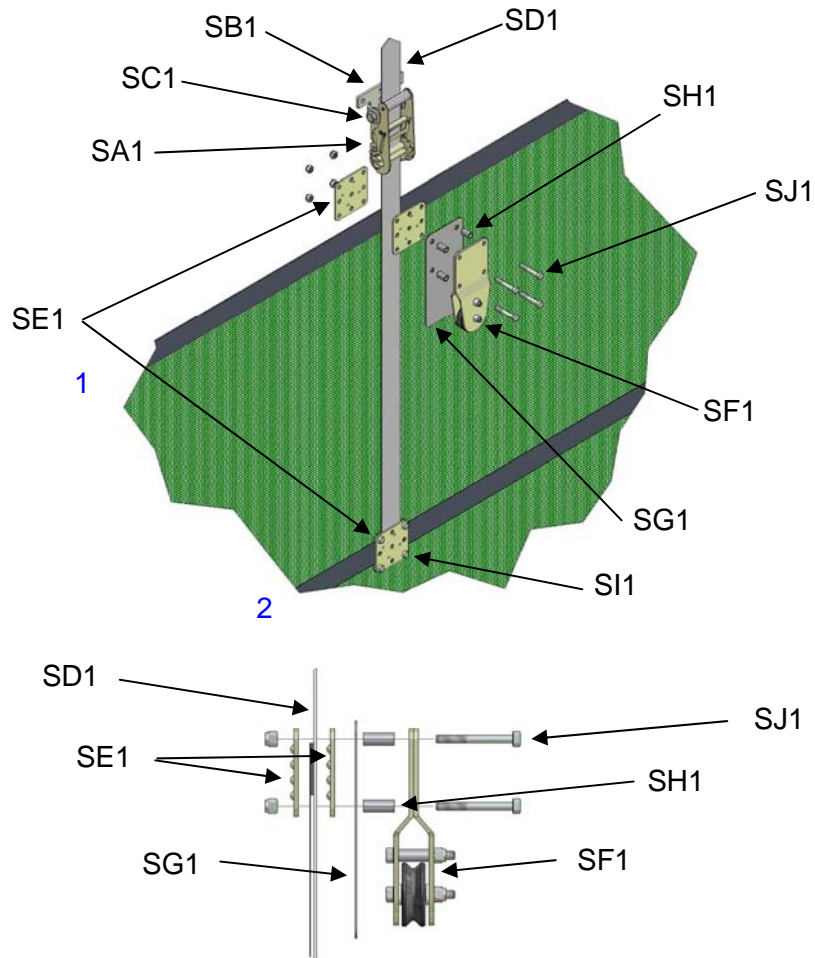

Figure 20

6.3 Referring to Figure 20. Fix vertical webbing strap (SD1) to second strap down on the door using the Clamp Plates (SE1) and M8 x 20 Bolts (S11) provided. Repeat process on top strap but use the M8 x 50 Bolts supplied (SJ1) and include the Wire Support Assembly (SF1), Spacers (SH1) and Wire Support Protection Pad (SG1). Feed webbing through ratchet and ensuring a minimum of 150mm of webbing is around the ratchet barrel operate handle to lift the door. Continue to adjust ratchet until top of door is level.

7. Setting Limit Switches, Testing and Finalising Drive

7.1 Using the Green and White Cam respectively set the Open and Closed Limits. When fully open the top Trolley should be a minimum of 50mm away from the Top Plates. To set the Closed Limit, lower the door until the Lifting Cable just begins to become slack.

7.2 To test the functionality of the Micro-Switches located in the Counterweight Containment Boxes, place an obstruction at least 1m tall on one track and close the door. When the blockage is met the Electric Drive will continue to operate until the Counterweight (D1) strikes the Micro-Switch. Open the door and repeat the test on the other side. If the Drive does not stop check the wiring and operation of Micro-Switch.

7.3 Single Phase

Inside the Control Box move DIL Switch 1 to ON, the door will now open in impulse mode. For Health and Safety reasons leave DIL Switch 2 OFF so the door closes in dead-man (push to run) mode.

Three Phase

The Controller will automatically set to open in impulse mode and close in dead-man mode

7.4 Open and close the door several times to allow the lifting cable to settle, and to check the door remains level. If adjustment is required use the eyebolts on the Lower Trolley (G1 and G2).

7.5 *CE Marking Electrically Operated Products under Machinery Directive*

It is the responsibility of the installer to check that the installation conforms to the specific safety features detailed in the Manufacturer's Installation Instructions, to issue the CE Declaration of Conformity and mark a power operated product under the Machinery Directive 2006/42/EC. To do this you will require the following which should be delivered with the product:

- 1) This set of Installation Instructions (*operating and maintenance instructions*)

- 2) Maintenance Log Book, (including Installation Checklist and Customer Declaration of Conformity)
- 3) 1 x Declaration of Conformity (Installer Copy) – to be completed
- 4) A CE Label

When CE marking a power operated Galebreaker product, it is vital to follow the steps outlined below:

ENG

- a) Install the product as per instructions, with no adaptations or modifications and complete of the *Health and Safety Checklist* in the Maintenance Log Book.
- b) Complete the two 'Declarations of Conformity' using the following:
 - **Model Type:** As shown on CE Label
 - **Serial Number:** As shown on CE Label
 - **Installation Company:** Your company name
 - **Date Installed:** Date Installed
 - **Declaration made by:** Responsible Person
 - **Declaration and Instructions received by:** Customer's Signature
- c) Fix the supplied CE label to the counterweight box. The label should be accessible / visible. Where the serial number does not incorporate the door size, add the Product width and Product height to the end of serial number using a permanent marker pen. i.e. the full serial number should read

Serial Number: 1234 / MDE W X H

[W] Product Width (m)

[H] Product Height (m)

- d) Your customer must be given a copy of the completed 'Maintenance Log Book' along with the 'Installation Instructions' supplied by Galebreaker. These should be stored adjacent to the door controls for reference purposes.

- e) Finally, ask your customer to sign the 'Declaration of Conformity' (Installer Copy). This important document must be filed back at the office of the installer for future reference



ATTENTION: Use of motors or controllers that are not supplied by Galebreaker, will make the installer the manufacturer (as defined by the Machine Directive 2006/42/EC) of the system and will require the installer to produce their own 'EC Declaration of Conformity' and product 'CE label'.

In such circumstances the door supplied by Galebreaker becomes a partly completed machine and therefore a Certificate of Incorporation can be supplied on request. The installer MUST NOT use the CE documentation supplied by Galebreaker.

ENG

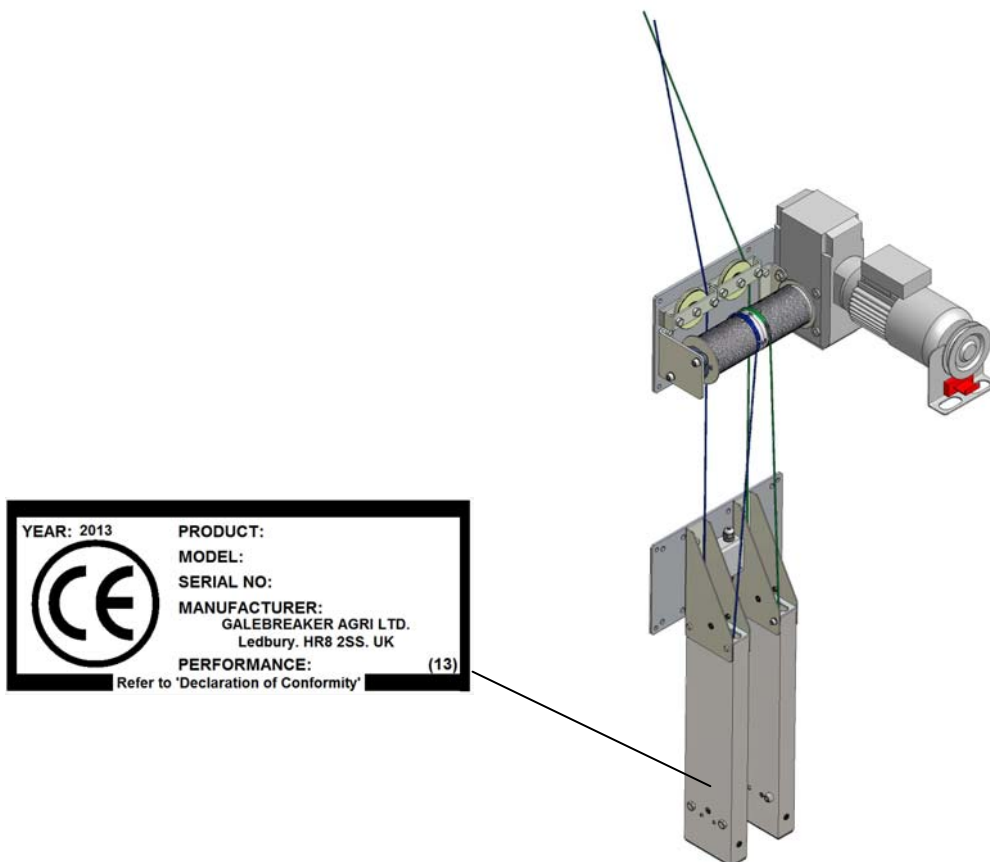

YOUR DOOR IS READY FOR USE

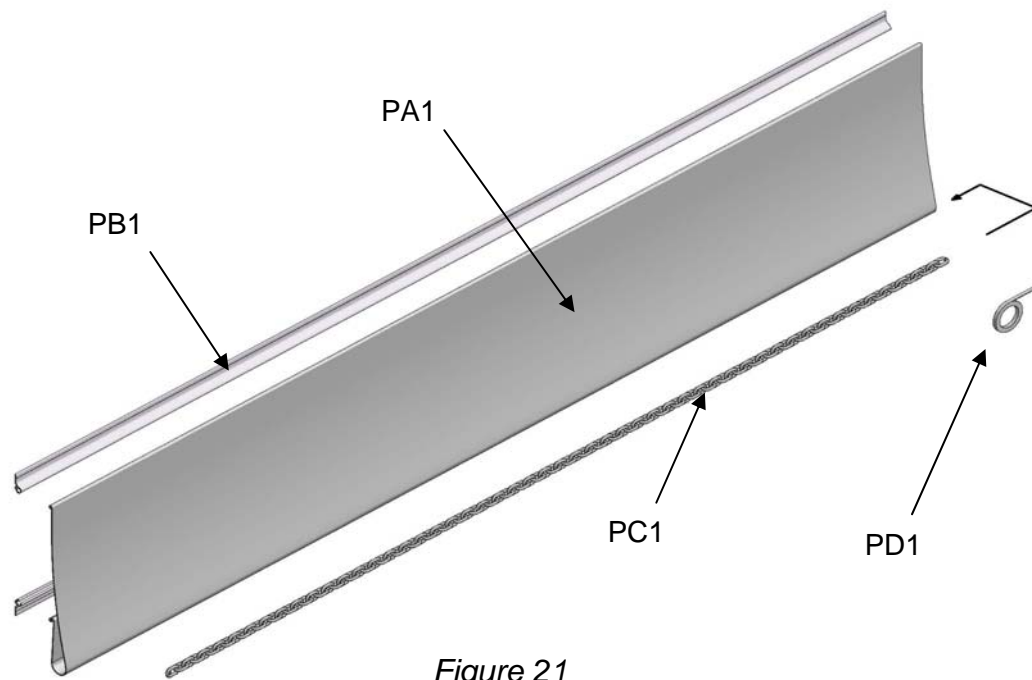

ENG

Figure 21

Table 4: Parts List for Optional Pelmet

FIGURE 21 REF:	QTY	DESCRIPTION
PA1	1	Pelmet Panel
PB1	*	Aluminium Kador Profile
PC1	1	Chain Weight
PD1	1	Pull Strap for Chain
PE1	*	M5.5 x 50mm Self Drilling Screws

* Quantity according to size of Pelmet

Additional Items Required by Installer

Self Drilling Screws are supplied to fix the Aluminium Profile to steel every meter, alternative fastenings required if fixing to a wooden or concrete building.

8. Installing Pelmet

8.1 Overview: With the flutes facing each other fix Aluminium Profile (PB1) to building with M5.5 x 50 Screws (PE1) at 1m centres. Align the upper section with the top of the Tracking and the lower section to the top of the door opening (Figure 22). To allow the Panel (PA1) to be fed into the Profile do not secure the last 2m.

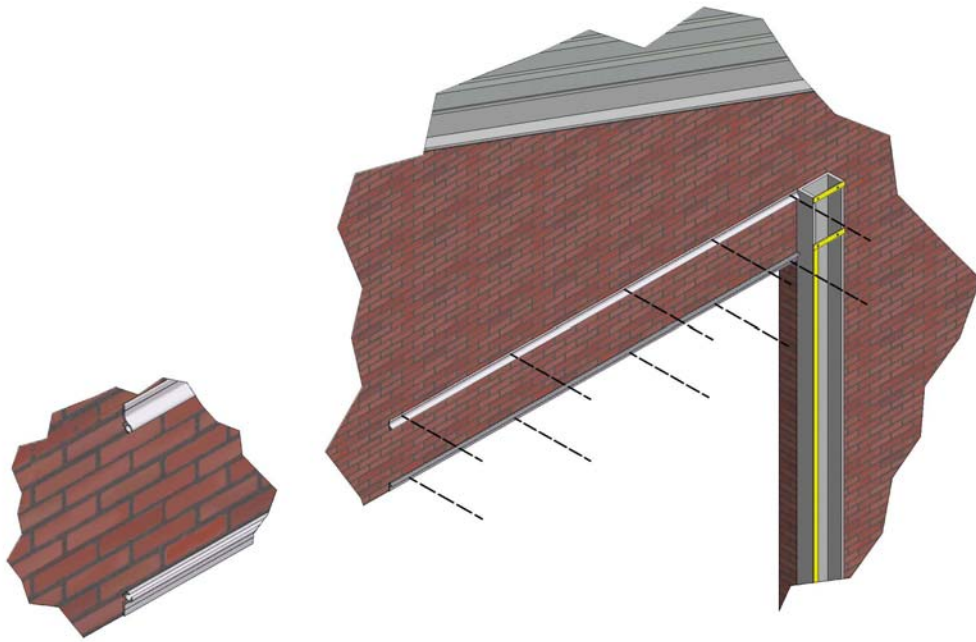

Figure 22

8.2 Mark the Pelmet (PA1) 50mm in from one end and 100mm up from the base, cut slot 15mm to 20mm long and tie Pull Strap (PD1) through slot. Feed Panel into Profile (Figure 23) and cut to length if required, ensuring the cut end is within 50mm of the Tracking. Secure last 2m of Profile with fix every 1m.

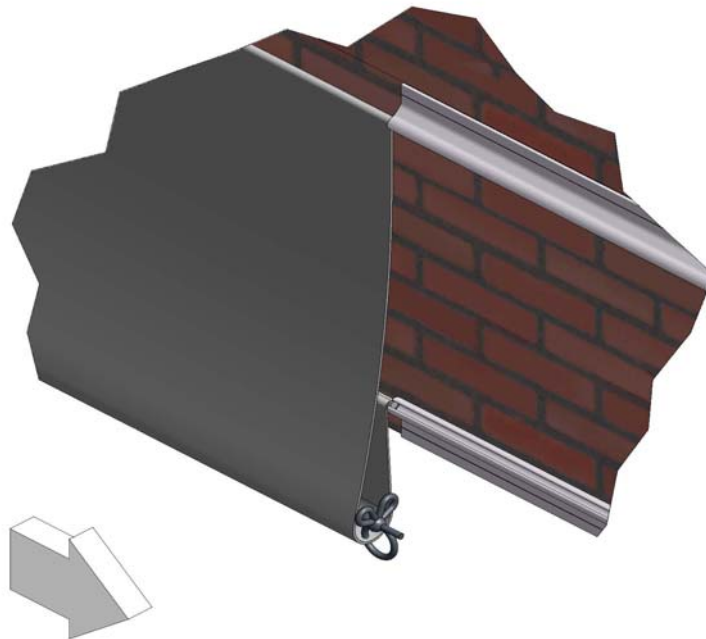
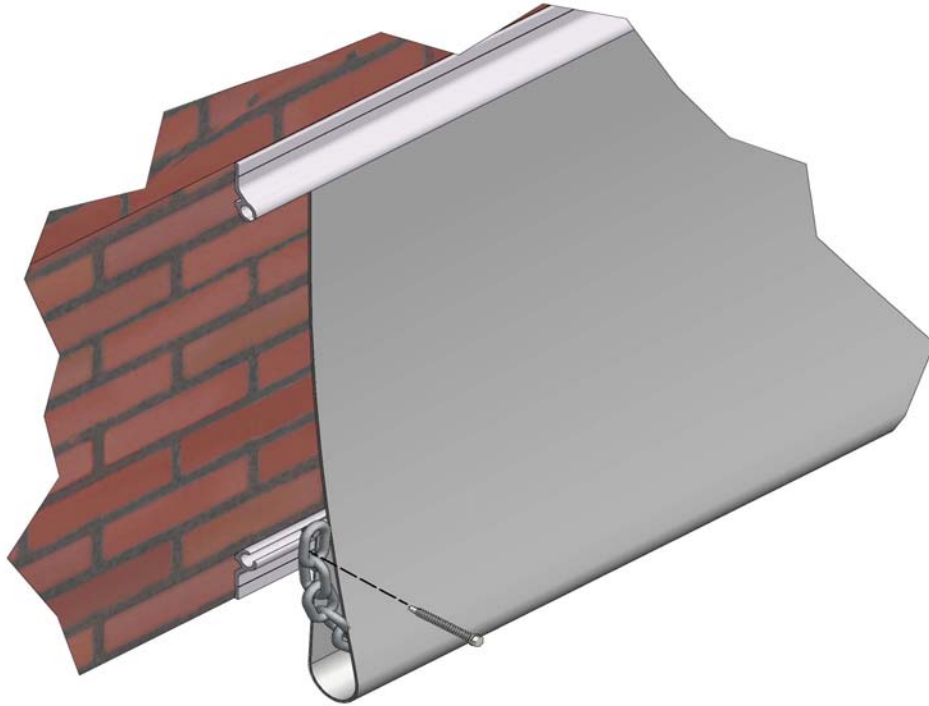

Figure 23

8.3 Tie Chain Weight (PC1) to loose end of Pull Strap and feed through loop in Panel. Cut Chain to length and secure in place at each end with a M5.5 x 50 Screw through the Profile (Figure 24).



ENG

Figure 24

9. Adjacent Drives

Table 5: Changed and New Parts

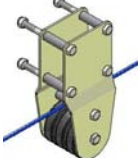
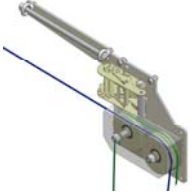
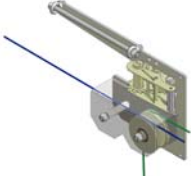
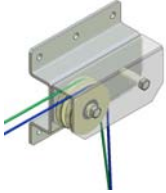
DOOR LOCATION	DESCRIPTION	STANDARD PART	OPTIONAL PART
Nearest to Drive (Only if width > 10M)	Replacement: Wire Support Assembly	 1 or 2 Single Pulley (SF1)	 1 or 2 Triple Pulley (SF3)
	Replacement: Longer Bolts to Secure above	4 or 8 M8 x 50. (SJ1)	4 or 8 M8 x 90 (SJ2)
Furthest from Drive	Replacement: Right Hand Top Plate Assembly #	 (G1)	 (G3)
	Additional: 90 Degree Corner Pulley	None	 (G4)
	Additional: Bolts to Secure Corner Pulley	None	4 M10 x 50
	Additional: Cable to Reach Drives	(H1)	(H1)

Left hand Top Plate Assembly if Left hand drive ordered

Door Nearest Drive

9.1 Replacing Section 3.4: Thread Cables through hole in Intermediate Trolleys (Figure 7.2), around the pair of Top Plates (Figures 7.3 and 7.4). Pay particular attention to the Cable routing on the right-hand Top Plate (Figure 7.4). Referring to Figure 8, continue Cables around 100mm pulleys on the Electric Drive down through Counterweight Plate, around Counterweights (D1) and back up to the Drive. Ensure the Left and Right Cables are positioned as indicated.

Doors over 10m wide with Additional Top Support(s):

Follow the details above, but include the Triple Wire Support Assembly(s) SF3 when passing the Cable between the pair of Top Plates (Figure 25). Ensure the nuts face away from the Door Panel and the cable passes through pulley nearest to the Door Panel.

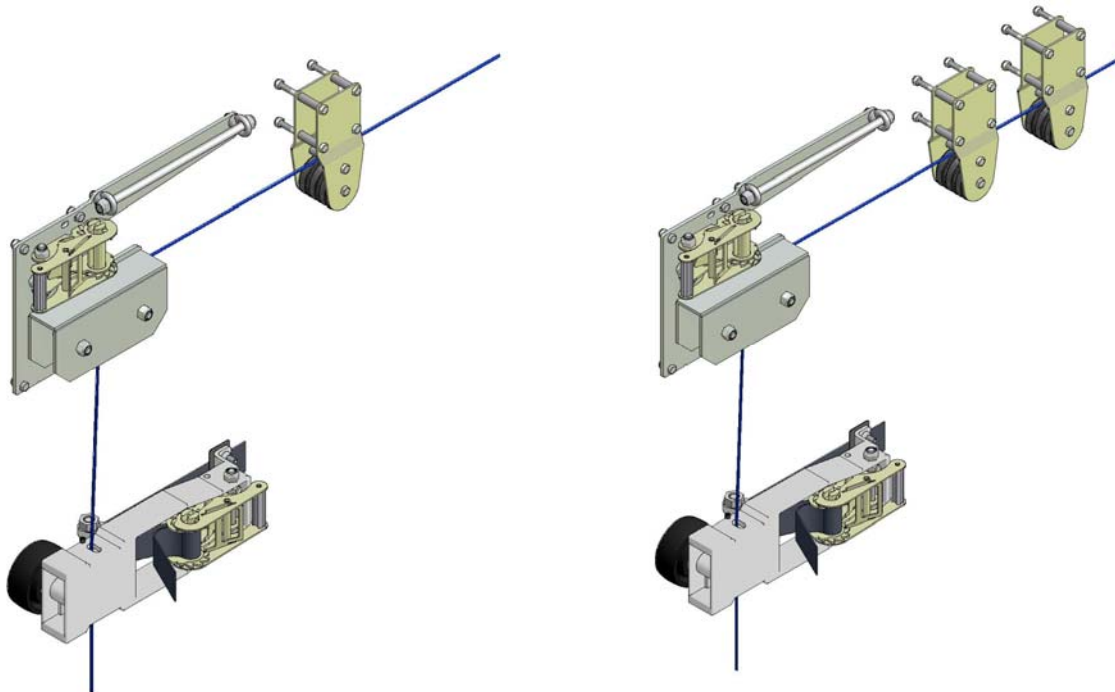

Figure 25

Door Furthest from Drive

9.2 Replacing Section 2.1: Top Plate Assembly: Bolt the Top Plates (G1 and G3) to the pre-installed brackets on the Tracking top with the eight M8 x 30 bolts supplied (Figure 26). Note that Top Plate G3 has a 'W' shape on the pulley bracket.

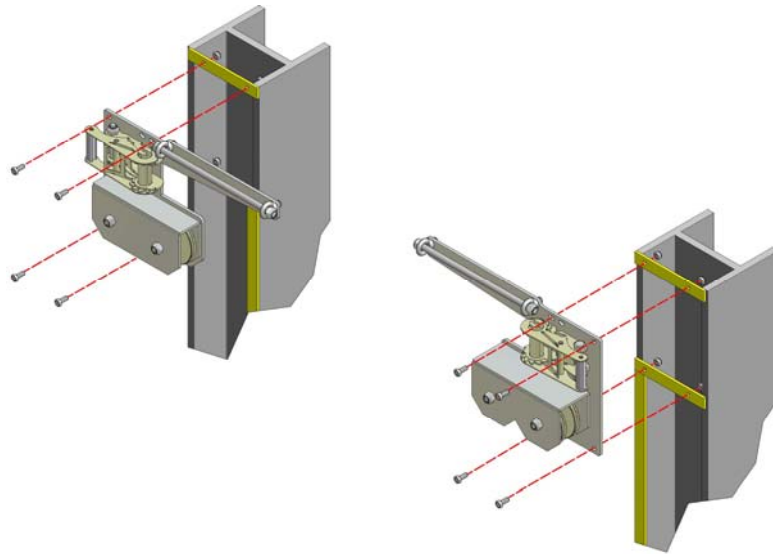

Figure 26

9.3 Additional Corner Pulley replacing Section 2.2: Referring to Figure 27 fasten Corner Pulley ensuring the distance from the edge of the Drive Plate is 540mm. Four M10 x 50 Bolts are supplied to secure Corner Pulley plates to a metal surface up to 25mm thick. (i.e. Plate, Channel, H-Beam, etc). Customer needs to supply own fastenings if securing to wood or concrete. Ensure the mounting surface can withstand the maximum door weight of 350kg.

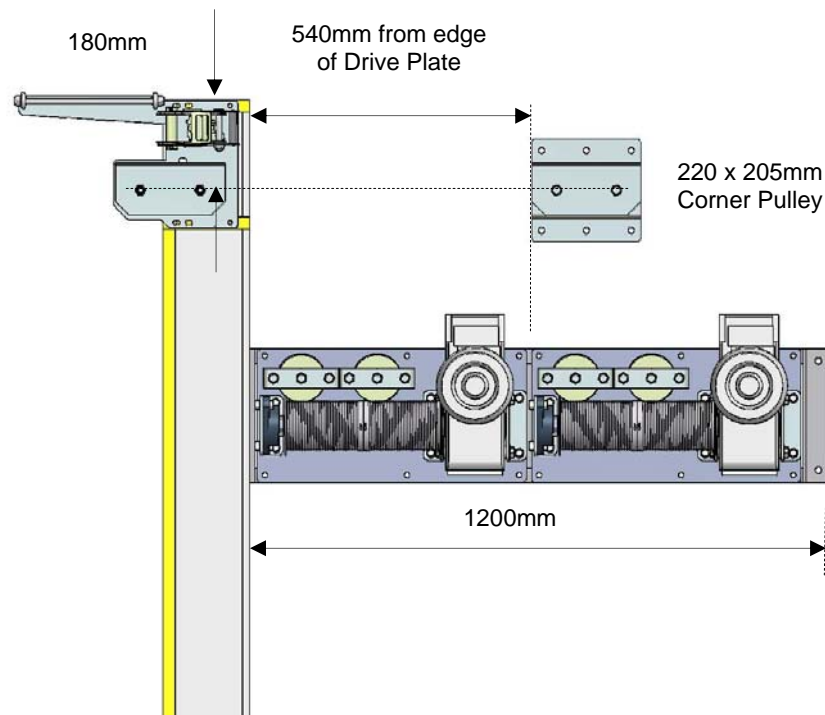
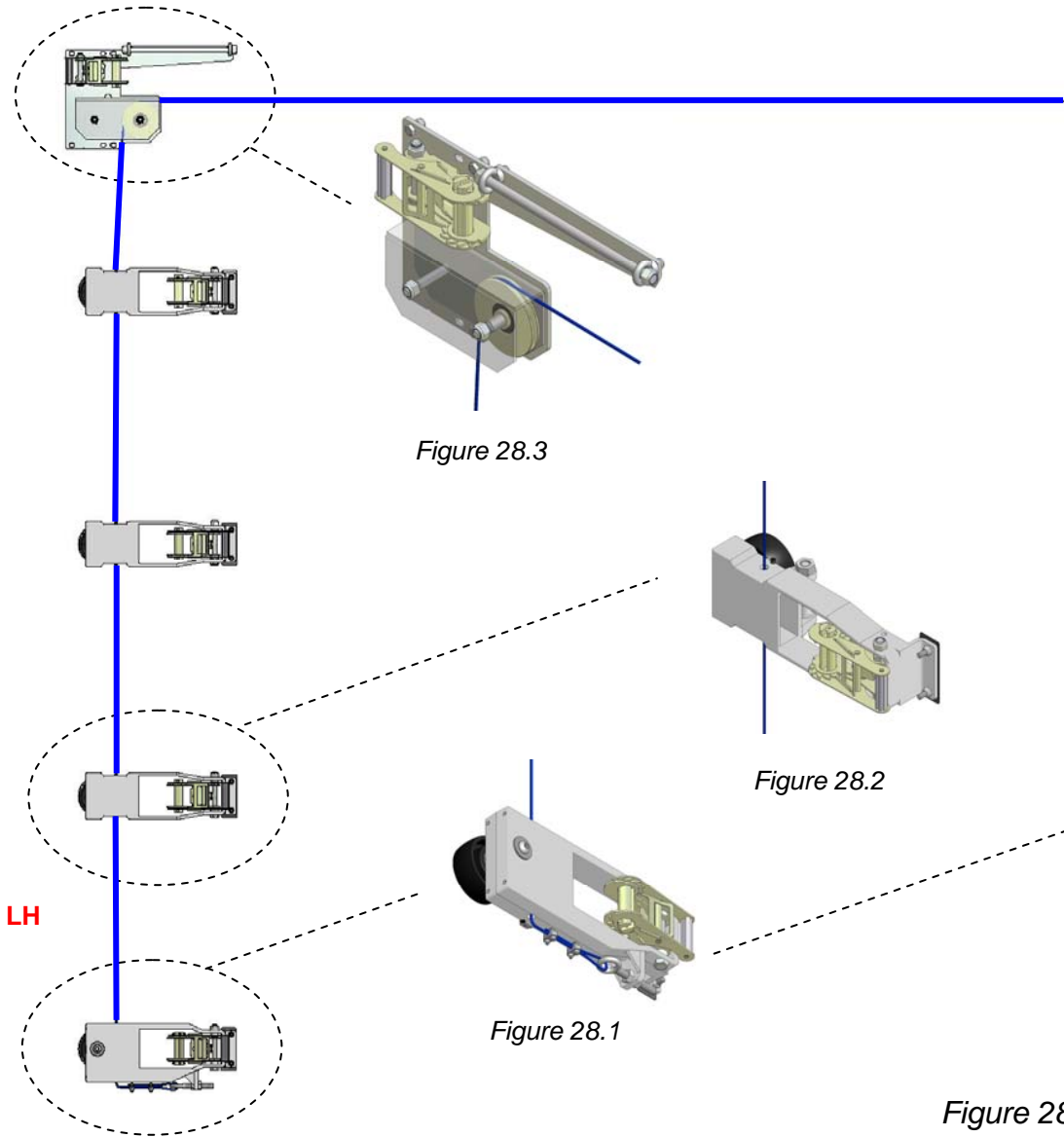

Figure 27



9.4 Replacing Section 3.3: Thread cables (H1) as indicated in Figures 28 and 29. Start at the Lower Trolley and wrap the cable around the adjusting eyebolt and secure with two 5mm Cable Grips (supplied), ensure the bridge section of the grip is against the cable under tension, (Figure 28.4).



CAUTION: Ensure the Cable Grips are correctly used and fully tightened. Failure could result in the door falling off the building, potentially injuring operators and bystanders

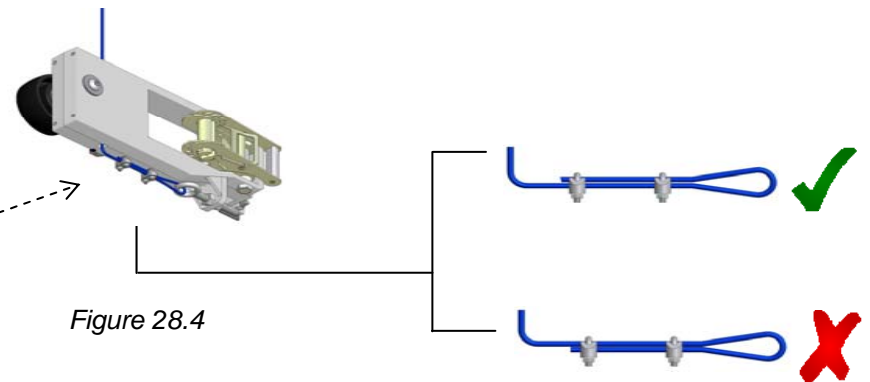
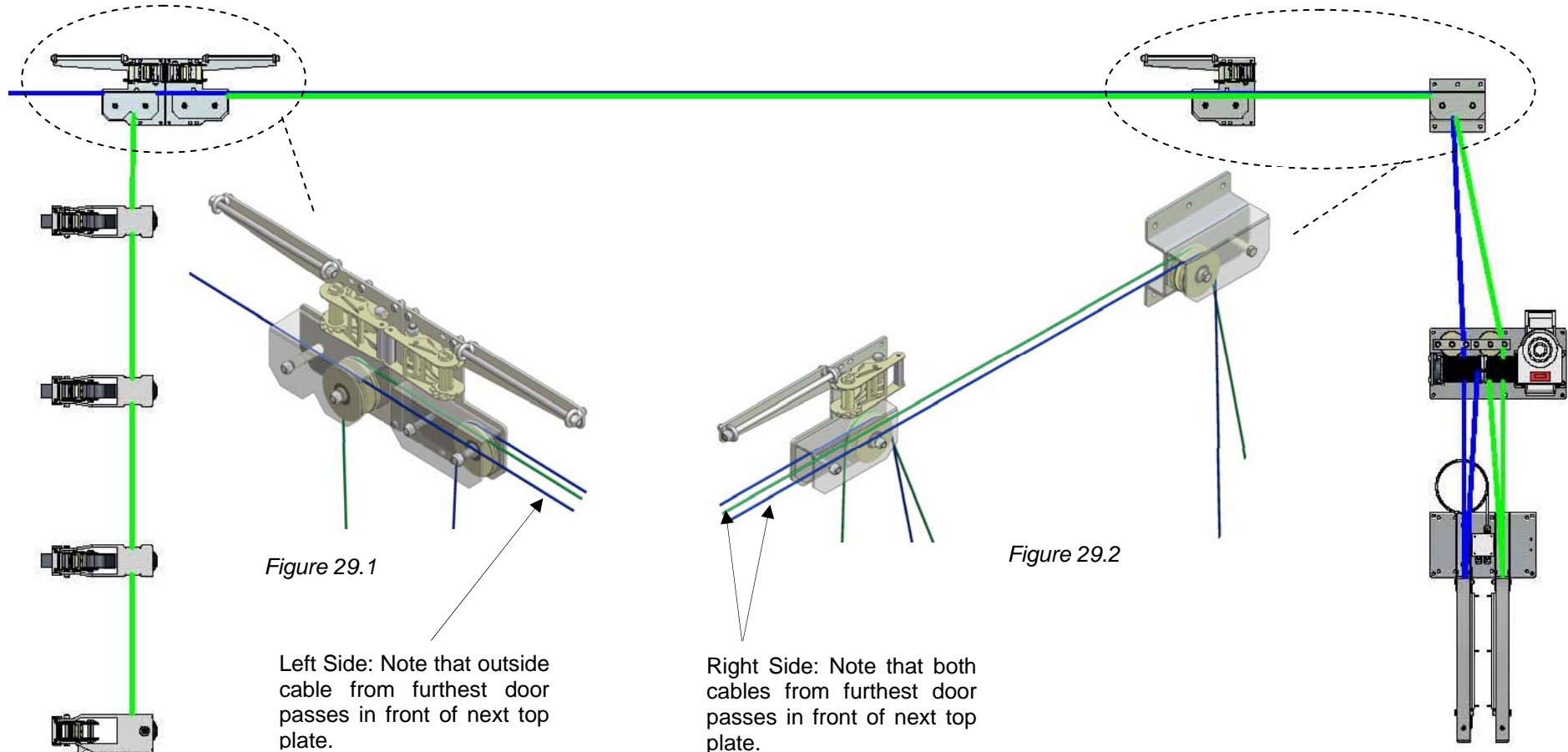

Figure 28



9.5 Replacing Section 6.2: Fix the Ratchet (SA1) to the Ratchet Bracket (SB1) with the M12 x 90mm bolt (SC1) provided. The standard fitting of the ratchet bracket is depicted in Figure 30, but it can be reversed if vertical mounting space is limited. Fit assembly to the building with three fixings, minimum size 8mm.

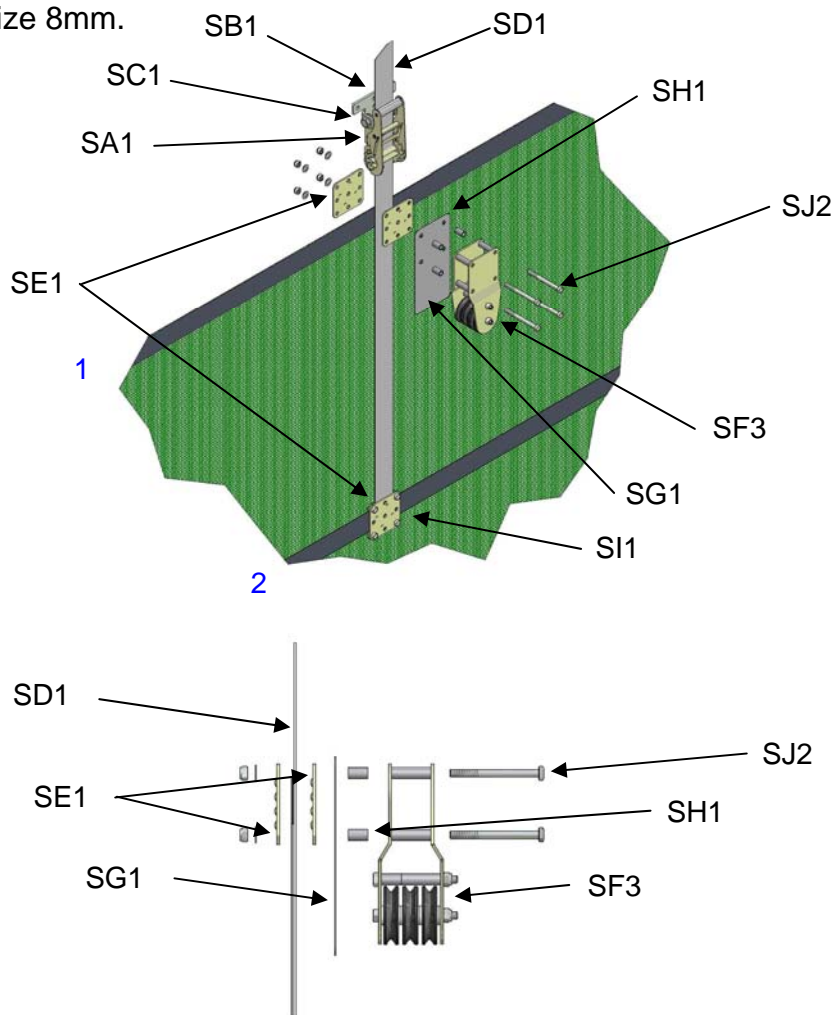

Figure 30

9.6 Replacing Section 6.3: Referring to Figure 30. Fix vertical webbing strap (SD1) to second strap down on the door using the Clamp Plates (SE1) and M8 x 20 Bolts (SI1) provided. Repeat process on top strap but use the M8 x 90 Bolts supplied (SJ2) and include the Wire Support Assembly (SF3), Spacers (SH1) and Wire Support Protection Pad (SG1). Feed webbing through ratchet and ensuring a minimum of 150mm of webbing is around the ratchet barrel operate handle to lift the door. Continue to adjust ratchet until top of door is level.

OPERATION AND MAINTENANCE

10. Operation

10.1 Press the Open and Closed Buttons to raise or lower the door. For Health and Safety reasons the door has to close in a dead-man (push to run) mode. The Drive is self-braking and will hold the curtain at any required position.

ENG

10.2 Electric power or motor failure: To manually operate the door first release the Motor brake before lifting the Hand Chain over the Chain-Wheel as shown in Figure 31. Pull the chain to operate the door. With the chain off the Micro-Switch the motor will not operate.

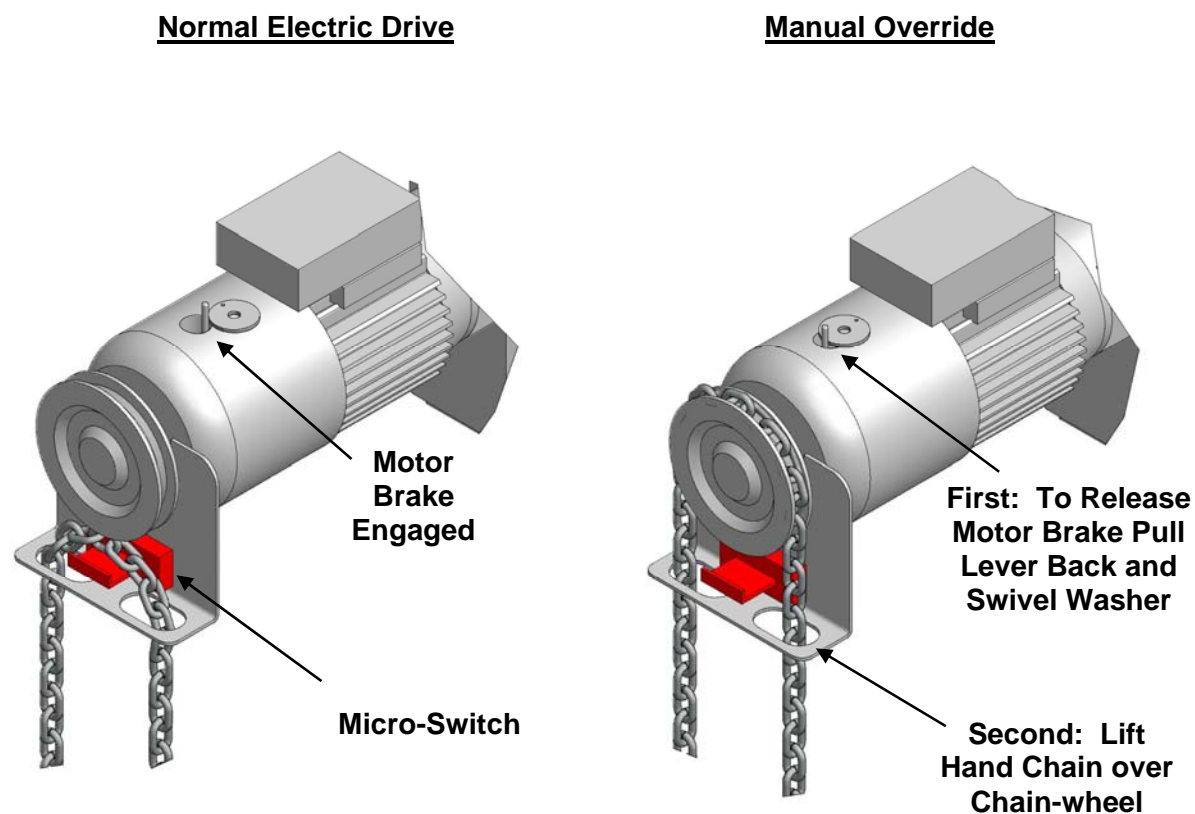

Figure 31



ATTENTION: It is vital that the door is fully closed when the wind speed is above 32kph / 20mph

Important Safety Information

- This door must only be operated by users familiar with its operation.
- When operating the door do not place fingers near the trolleys or other moving parts at any time.
- The person operating the door must have the door in sight at all times during its operation.
- Do not permit children to play with the door or its electrical controls.
- Do not modify or attach any objects to the door as this may cause damage and/or injury.
- Operate the door only when properly adjusted and free from obstructions.
- Should the door become difficult to operate or inoperable, consult your local dealer. Repairs should only be carried out by competent personnel.

11. Maintenance

11.1 Annually: Check the Lifting Cables for fray and damage. Replace suspect items to ensure it is safe for operators and bystanders alike.

11.2. Annually: Check for corrosion of the supporting bolts for the Electric Drive (B1), Counterweight Plate (C1) and adjusting eyebolt on the Lower Trolley (G1 and G2). Replace suspect items to ensure it is safe for operators and bystanders alike.

11.3 Annually: Check the door lifts evenly - tighten and adjust Lifting Cable as appropriate.

11.4 If the curtain material is damaged, repair with special repair kit (code SPS-99) available from your Galebreaker Dealer, Importer or Head Office.

12. How to Dismantle Your System

Follow the installation instructions in reverse order. In particular ensure the door is closed and there is no residual tension in the Lifting Cables before disconnecting from the Electric Drive.

To remove webbing from the ratchet pull release catch on handle and open 180 degrees until ratchet body is flat, pull on webbing strap. If Ratchet does not initially release, pull on webbing strap whilst moving handle between the 90 degree and 180 degree point.

ENG

NOTE: This product has been tested to European Standard EN 12424 with a Resistance to Wind Load rating of Class 5. Tried and tested in the harshest weather conditions, a summary of our guarantee is listed below, see our website for full details:

- **Mechanical components: 100% guarantee for two years, followed by an eight year graduated guarantee.**
- **Electrical components: 100% guarantee for two years, followed by a three year graduated guarantee.**

RAIN INGRESS: Please note that in extreme weather conditions some moisture will penetrate a mesh material.