

Electric Maxidoor[®]

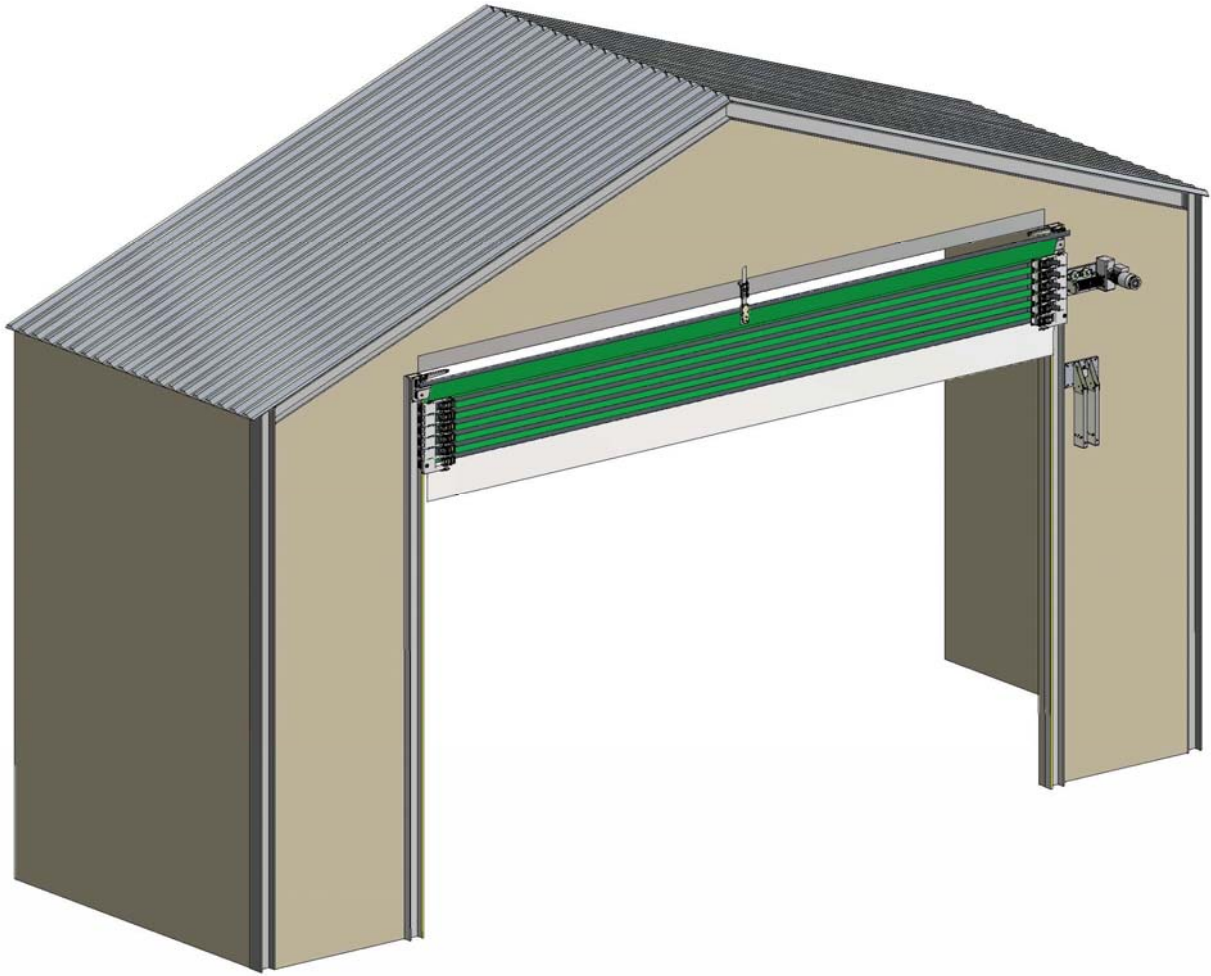

Pre-Installation Instructions

Galebreaker[®]
— AGRI —

1. Doors are manufactured to suit the opening, when ordering please supply **Width A** and **Height B**. Table 1 gives the access heights. **The Electric Drive can be fitted to either side, please state preference when ordering.** If preference not stated a right-hand drive (as shown in these instructions) will be supplied. Product overview is shown in Figure 1a.

ENG

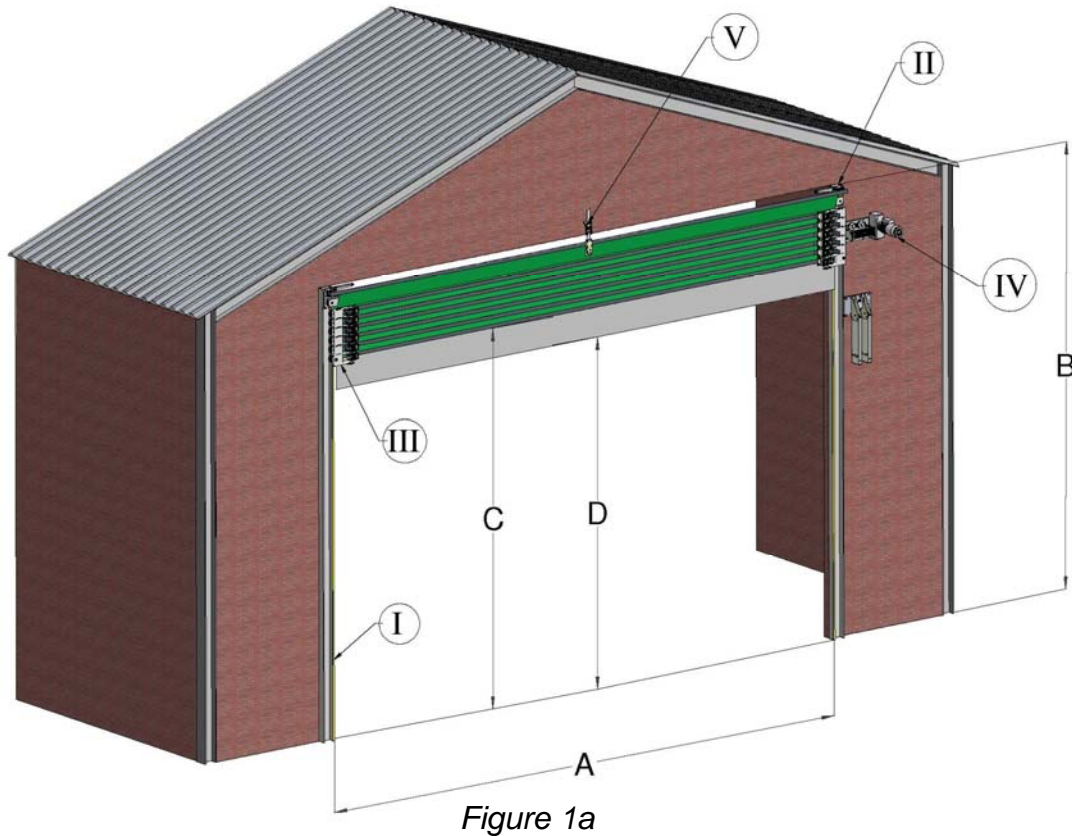

Table 1: Access Height

DOOR HEIGHT (M)	HEIGHT TO BOTTOM STRAP (M)	CLEAR OPENING HEIGHT (M)
B	C	D
Minimum Height for Electric Door = 3.2m		
3.2	2.585	2.135
4.1	3.365	2.915
5.1	4.245	3.795
6.1	5.125	4.675
7.1	6.005	5.555
8.1	6.885	6.435
9.1	7.765	7.315
10.1	8.645	8.195



CAUTION: To safeguard against any danger points, the minimum height 'H' of any door is 3.2m.
 In the event of power or door failure, the door must not form the only means of exit from the building to which it is fitted.

ENG

2. Doors are designed to the following tolerances, Figure 1b refers:
 Width $A_T = A_B - 0\text{mm} / +20\text{mm}$. A_T can be in the range of 0mm to 20mm wider than A_B , but must not be smaller.
 Height $B = - 50\text{mm} / + 100\text{mm}$. Changes in floor level to be between 50mm narrower to 100mm taller.

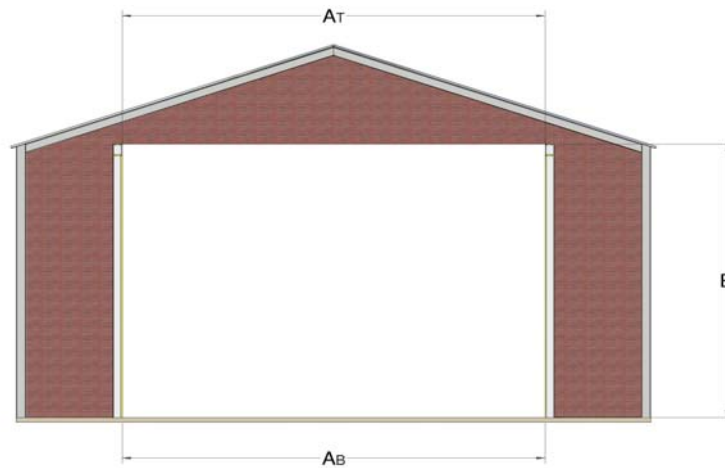

Figure 1b

Wind Loadings

The structure to which the door is fitted needs to be of adequate strength to resist the following wind loads.

Wind Speed (km/hr)	Wind Load (N)*	Wind Load (Kg)*
70 km/hr	= W x H x 233	= W x H x 24
100 km/hr	= W x H x 481	= W x H x 49
140km/hr	= W x H x 933	= W x H x 95

**No allowance made for safety margins*

3. Figure 2 and 3a indicates the recommended layouts and size of tracking. Ensure tracking is securely fixed to the building and/or ground. It is important that the track is installed vertically, the two sections are parallel, and that the tops are level. If you require further guidance on suggested size of track then contact Head Office

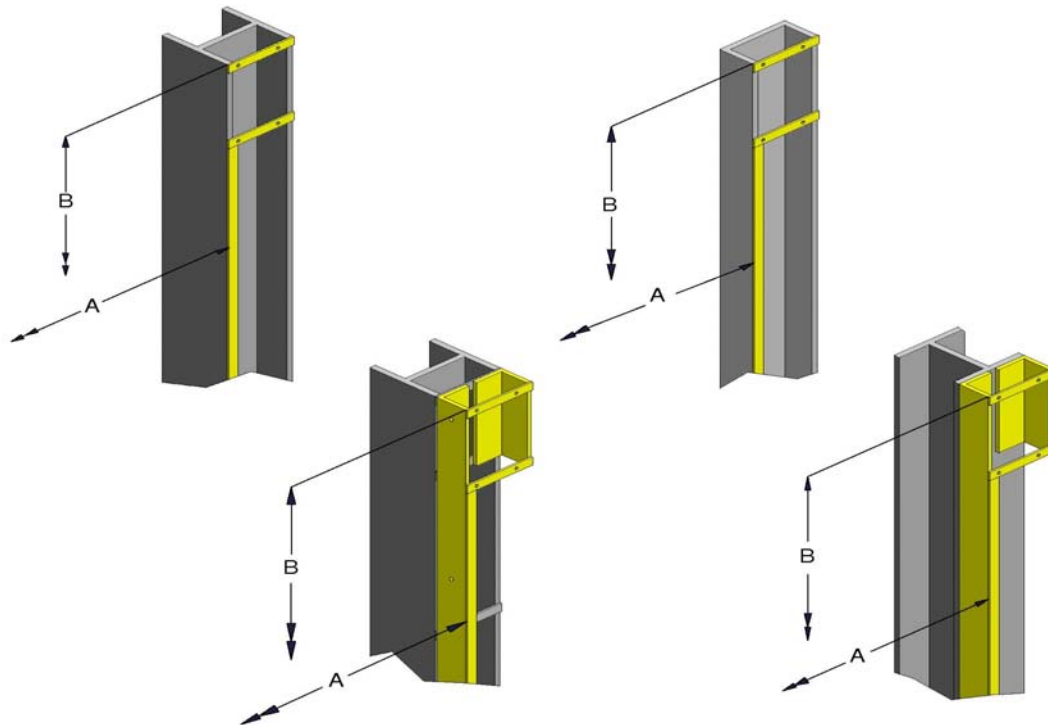



Figure 2

4. When fixing the trolley retaining lip onto the tracking, we recommend a 25mm weld every 250mm, continuous welding will generate too much heat and cause the tracking to twist.



Do not weld on the inner face of the tracking as this will obstruct the trolley wheel, see Figure 3b

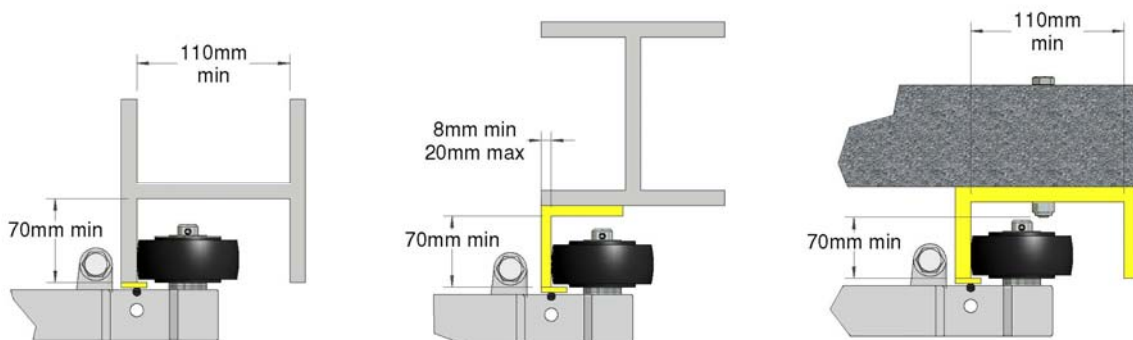
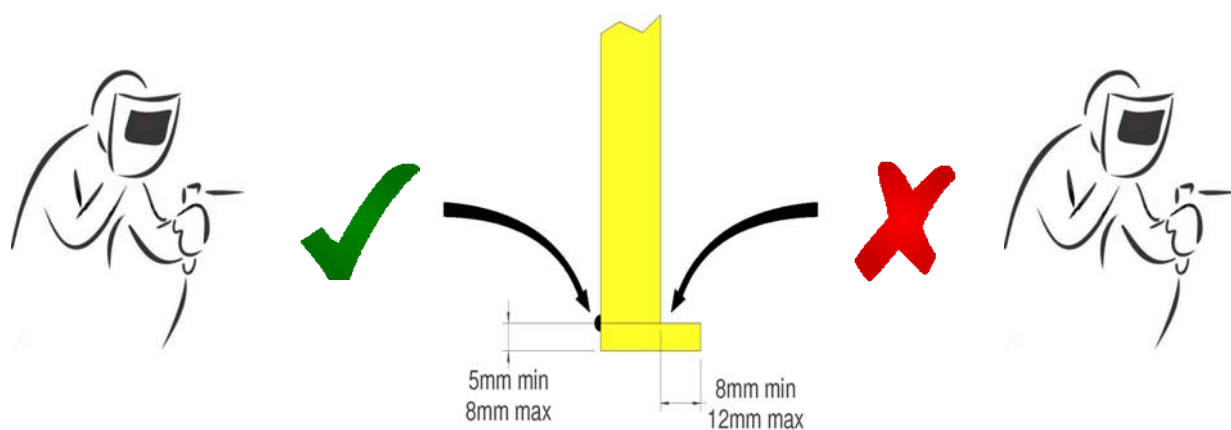

Figure 3a



ENG

Figure 3b

5. The position and size of the top fixing brackets are shown in Figure 4a and 4b; the four holes retain the top pulley and ratchet plate.

ENG

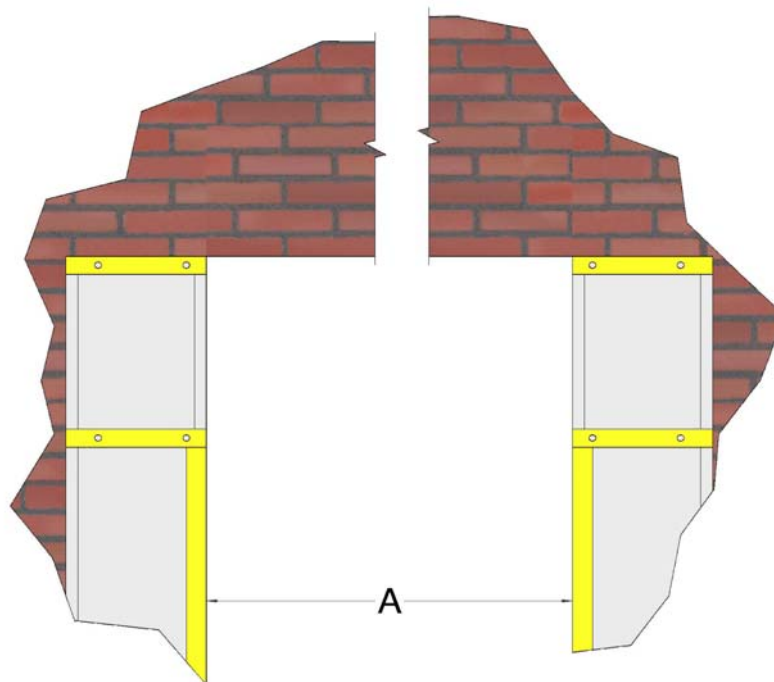
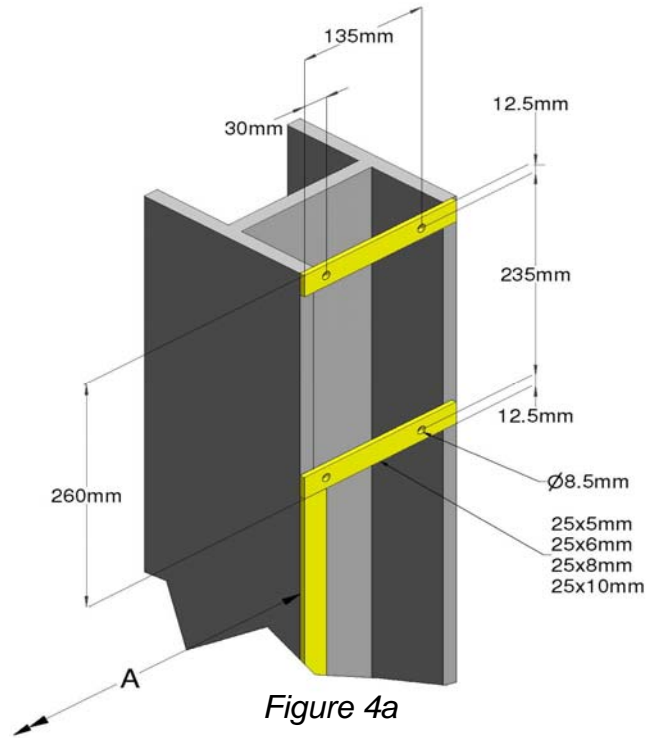

6. There must be a minimum of 300mm clearance either side of the tracking to provide sufficient space for the door panel to fold and to prevent damage by abrasion, see Figure 5. Check that there are no obstructions (gutters, downpipes, etc.) to hinder the operation of the door.

ENG

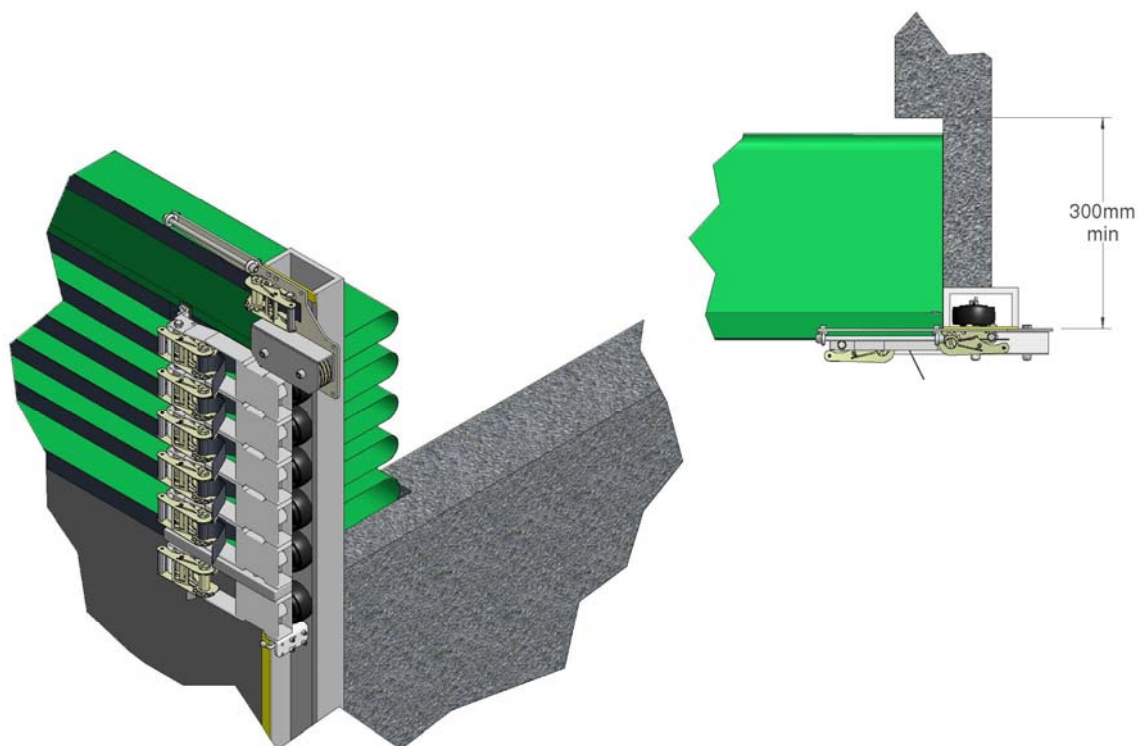

Figure 5

7. The position of the Electric Drive and Counterweight Plates for the various heights (B) of door are shown on Table 2 and Figure 6. Note for heights 3.2m to 3.8m the bottom of the counterweights are less than 2m above ground, and measures will need to be taken by the customer to prevent operators and bystanders making contact with them.

ENG

Table 2: Position of Mounting Plates in relation to Height

Reference:	3.2m < B < 4.1m	4.1m < B < 7.1m	7.1m < B < 10.1m
G	250mm	Min = 450mm	Min = 750mm
H	500mm	Min = 750mm	Min = 2,000mm
I		Min = 2,900mm	Min = 2,900mm

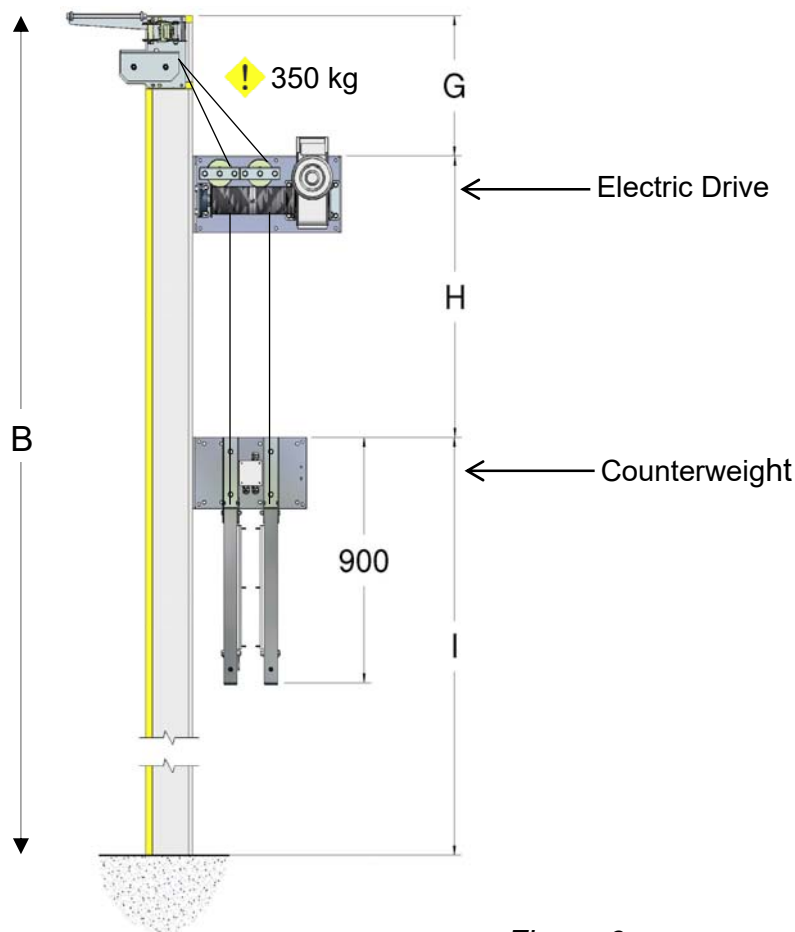

Figure 6

7.1 Ensure there is a power supply with LOCKABLE isolator within 1m of the Electric Drive, specification required:

Single Phase = 230V, 750W, 5.2 Amps

Three Phase = 400V, 1500W, 3.2 Amps

8. The brackets to support the Electric Drive and Counterweight Plates can be supplied by Galebreaker, see Figure 7a for the part number. Alternatively Point 9 details a suggested design for customer manufactured brackets. The mounting face of these brackets must align with the outside edge of the tracking (Figures 7b). Ensure the fixing surfaces are upright and can withstand the maximum door weight of 350Kg.

ENG

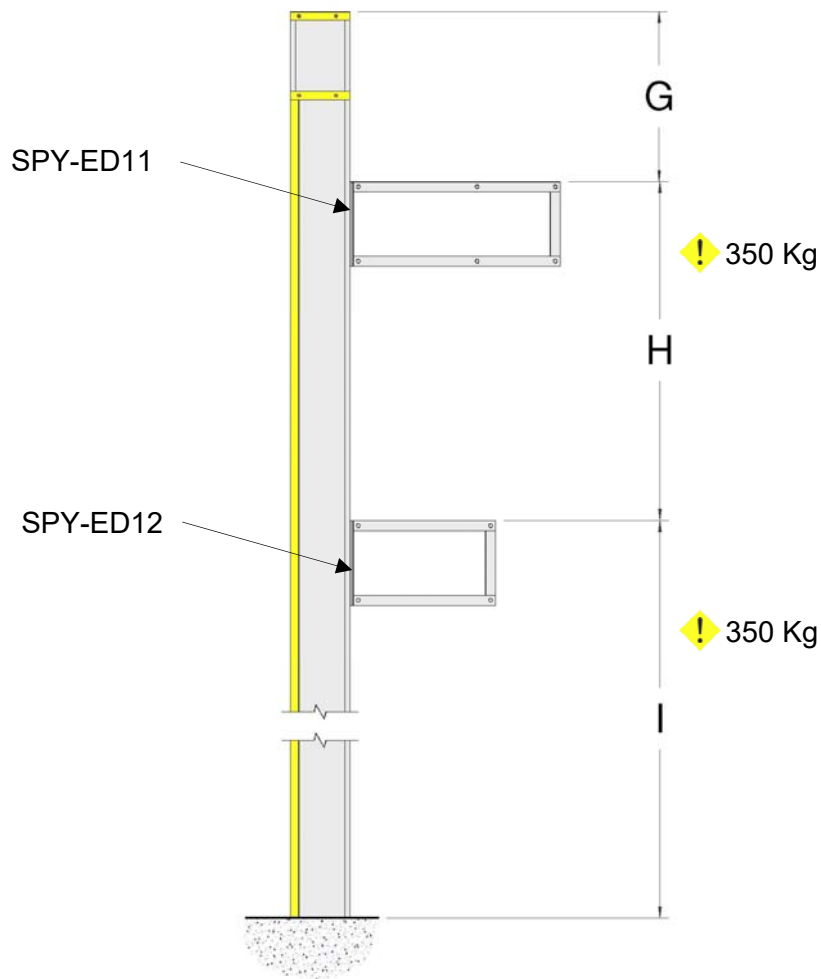

Figure 7a

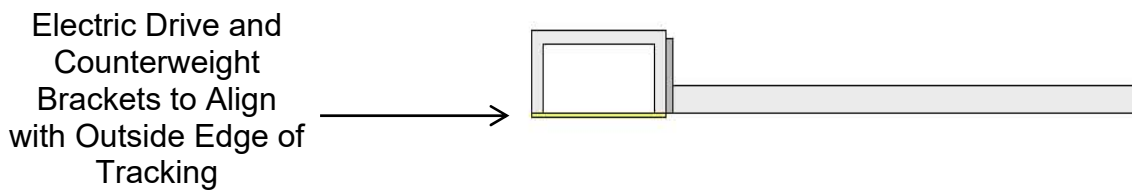

Figure 7b

9. Suggested design of the customer supplied brackets using steel profiles is shown in Figure 8a and 8b. If alternatives are used (larger box profile, or angle) ensure the central section indicated is clear of obstructions.

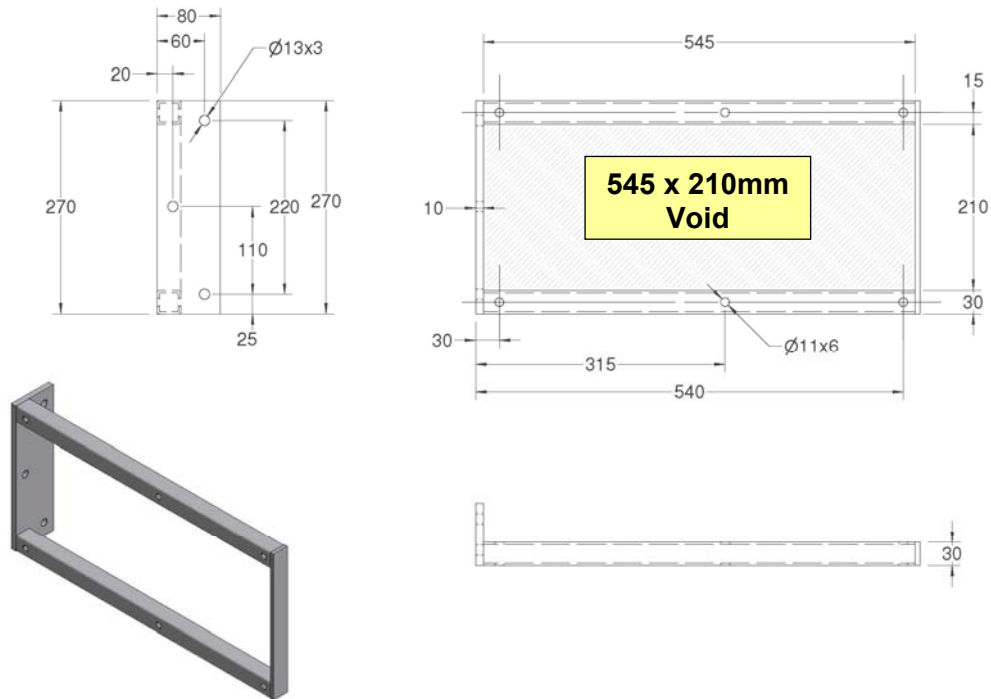

Figure 8a: Electric Drive Mounting Bracket

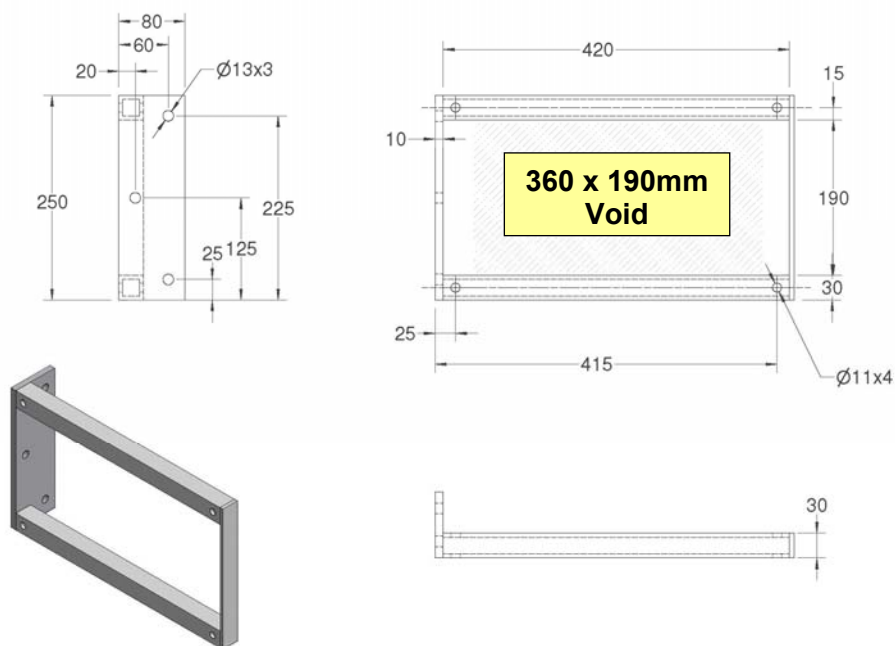

Figure 8b: Counterweight Mounting Bracket

10. Lifting Cable and Panel Support: Additional support(s) for the panel and lifting cable is supplied for doors over 10m wide in accordance with the Table 3. See Figures 9a and 9b. The inset drawing shows the footprint of the fixing bracket is 120 x 60mm.

Table 3: Quantity of Supports

DOOR WIDTH (A)	QUANTITY
0M -> 9.9M	0
10M -> 14.9M	1
15M -> 20M	2

ENG

10.1 Width 10m -> 14.9m: One Support

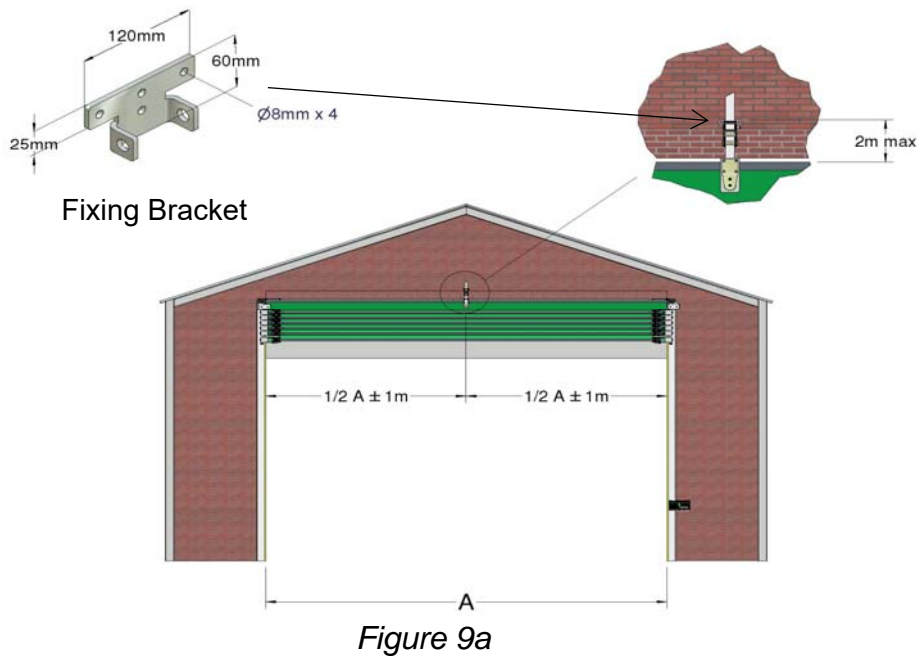

10.2 Width 15m -> 20m: Two Supports

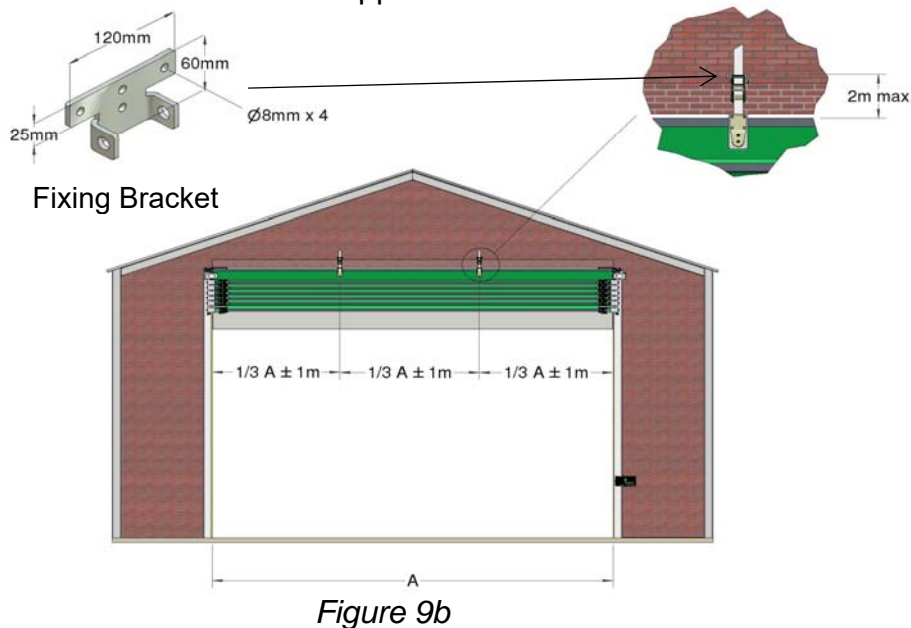

11. Figures 10a through to 10c show three electric drive fitting locations for adjacent doors.

- ❖ If the two drives can be positioned on extreme left and right then the minimum width of the central tracking is 250mm (Figure 10a).
- ❖ If one of the drives is to be mounted to the central column then the minimum width of the central column is 900mm (Figure 10b)
- ❖ If both drives are to be mounted on extreme left or right then the minimum width of the central tracking is 250mm, and approximately 1350mm is required to accommodate the adjacent drives (Figure 10c). If this option is required contact your Galebreaker Dealers, Distributor or Head Office for details of the additional parts.

ENG

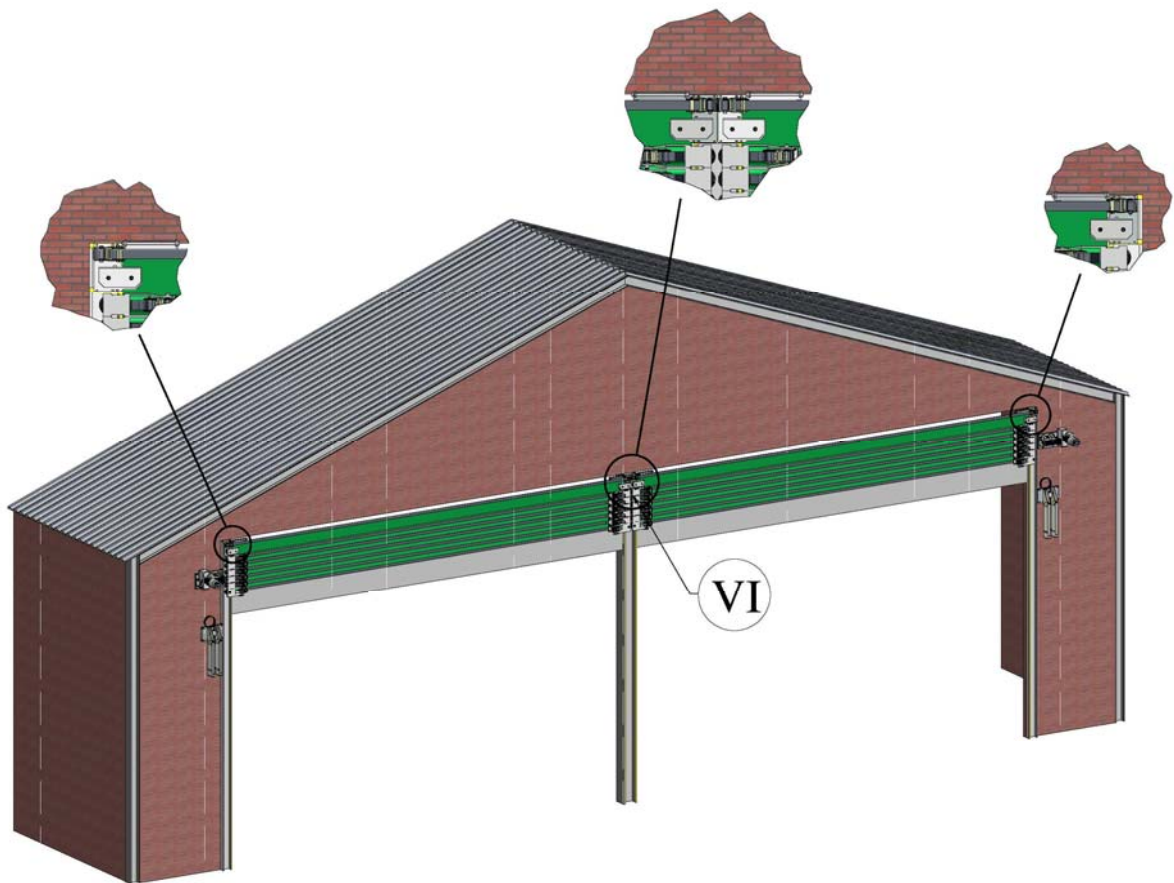

Figure 10a Drives on Left and Right

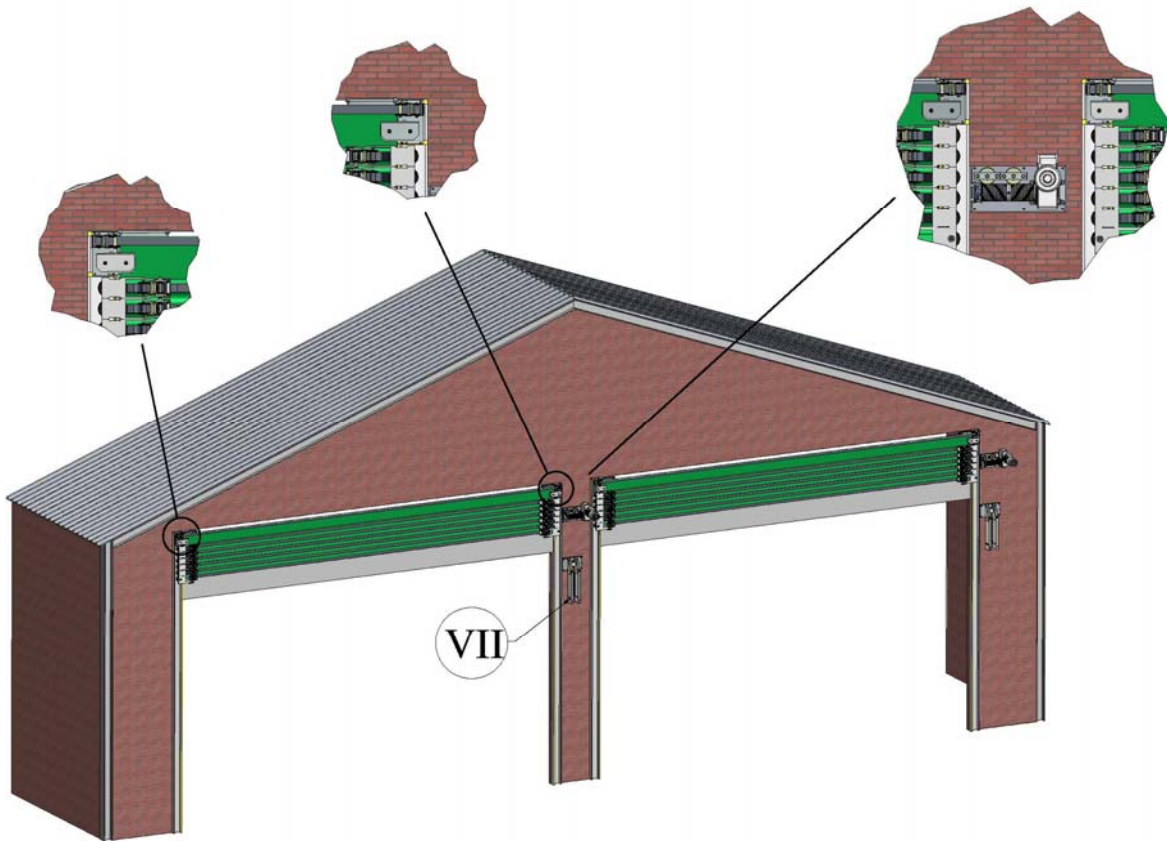

Figure 10b One Centrally Mounted Drive

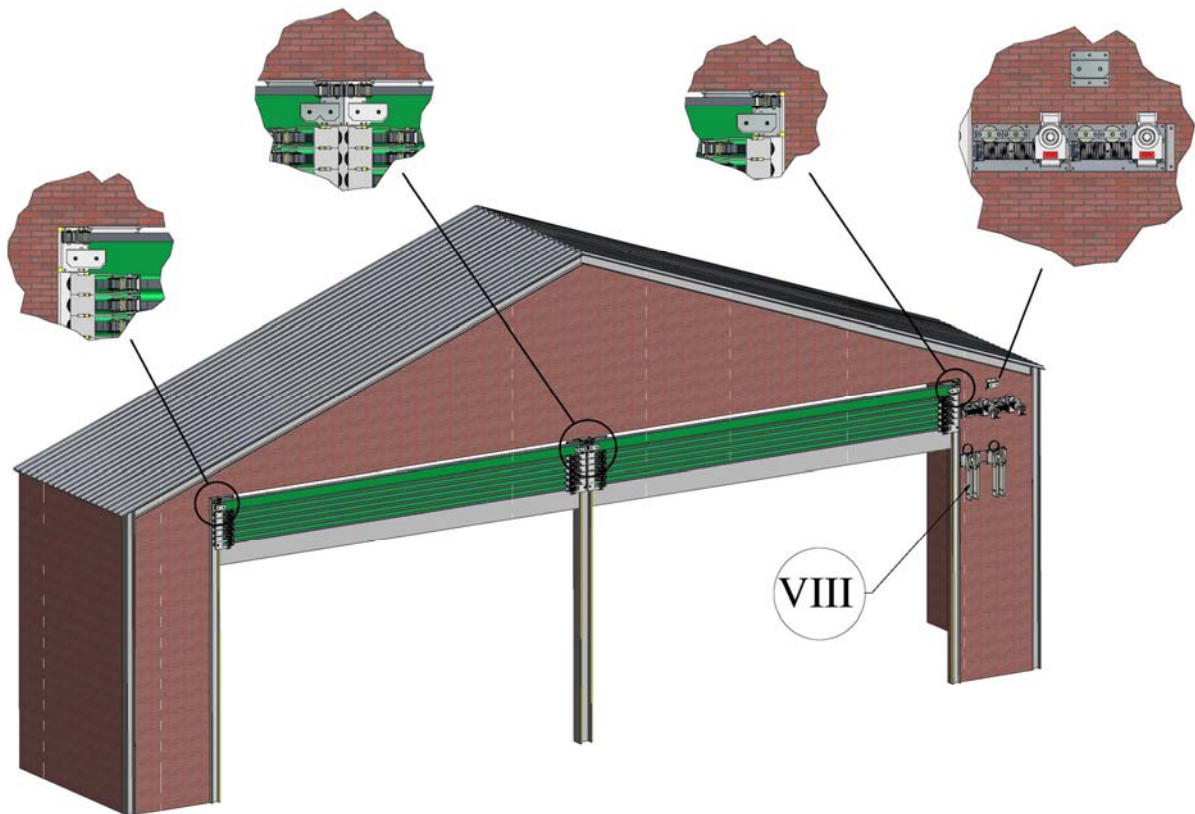

Figure 10c Adjacent Drives

12. Drives positioned on the extreme left and right: Detail of the central tracking is shown in Figure 11. The majority of the tracking details are the same as Area I. Of particular note is:

- ❖ Minimum tracking width of 250mm.
- ❖ Position and size of the top fixing brackets and the eight holes to retain the adjacent top pulley and ratchet plate.
- ❖ Retaining lip to both sides of the tracking

ENG

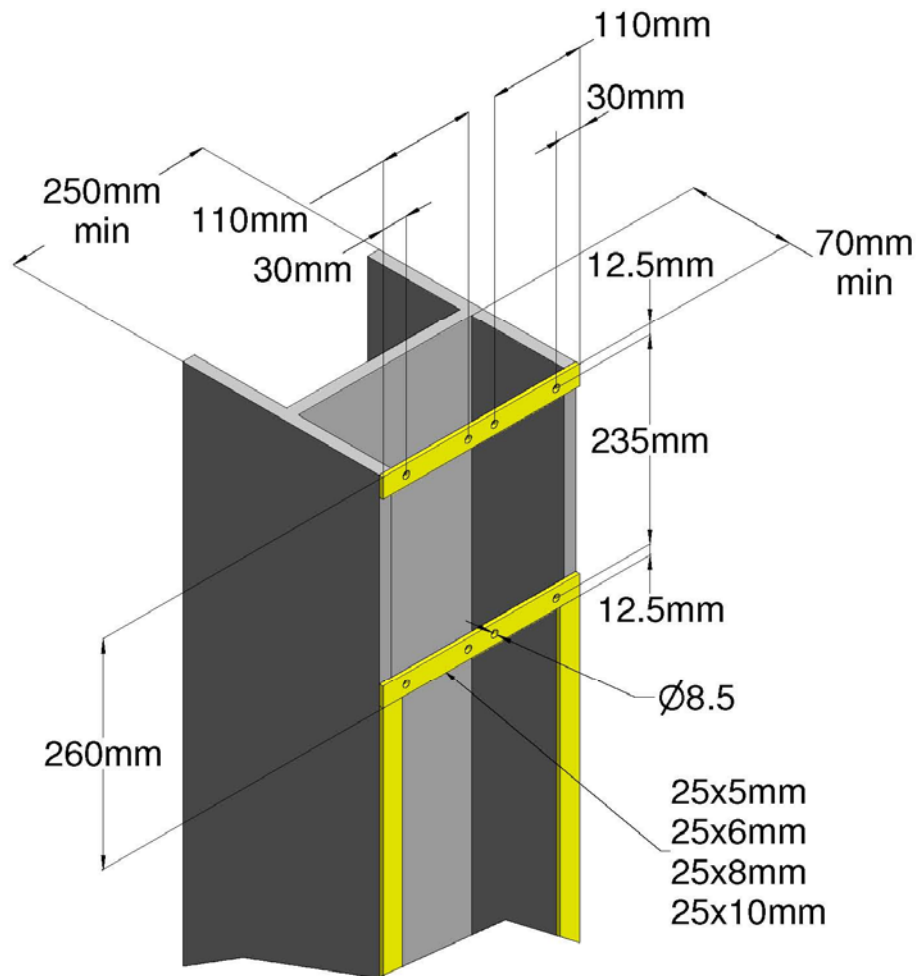
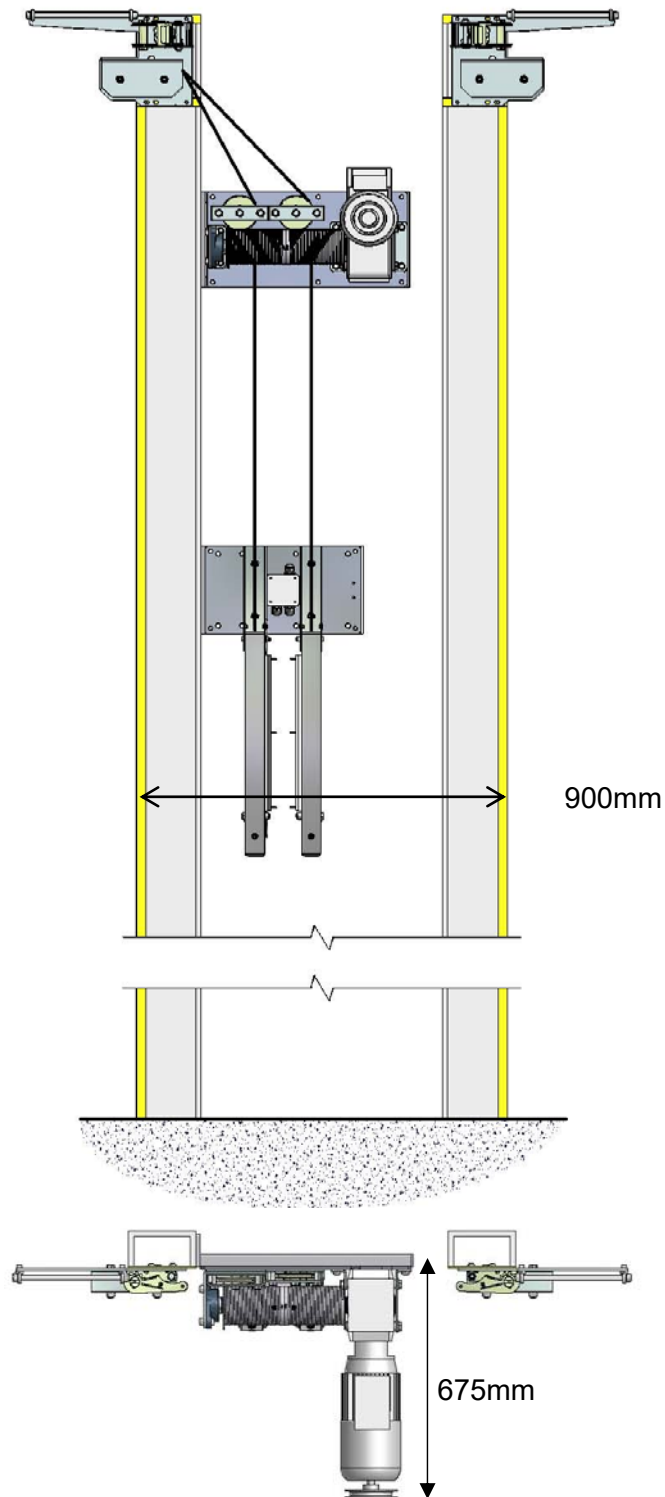

Figure 11

13. One drive centrally positioned: Suggestion for the central column based on two 150mm wide individual tracks, is shown in Figure 12. Each tracking is independent and details are the same as Area I. Of particular note is the minimum column width of 900mm to allow space for the Electric drive.



ENG

Figure 12

14. Adjacent Drives:

14.1 Central Tracking: Follow the details outlined in Point 12 above, minimum width of 250mm.

14.2 Drives: Suggestion of layout is shown in Figures 13a and 13b, Note that:

- ❖ Minimum width to accommodate both drives is 1350mm, assuming a track width of 150mm. Allowances have to be made for tracks above 150mm wide.
- ❖ Referring to Figure 13b the rules for dimensions of G, H and I in relation to height B as detailed in Point 7 and Figure 6 still apply.
- ❖ The fixing face of the corner pulley must align with the outside edge of the tracking, Figure 13a.
- ❖ The corner pulley will be mounted at the same level as the top bracket, Figure 13b.

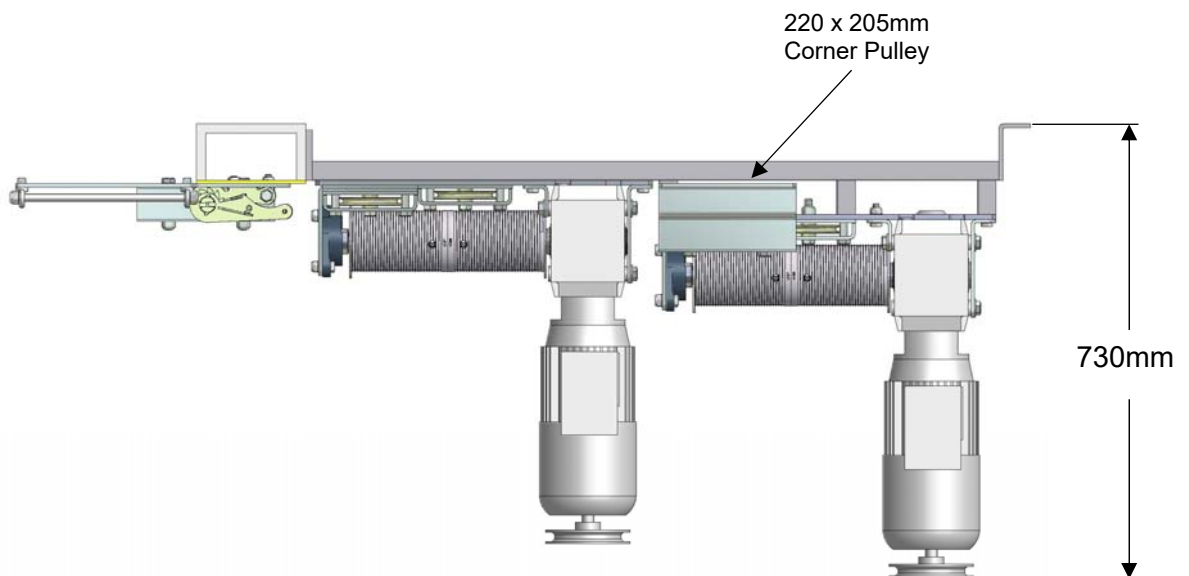

Figure 13a

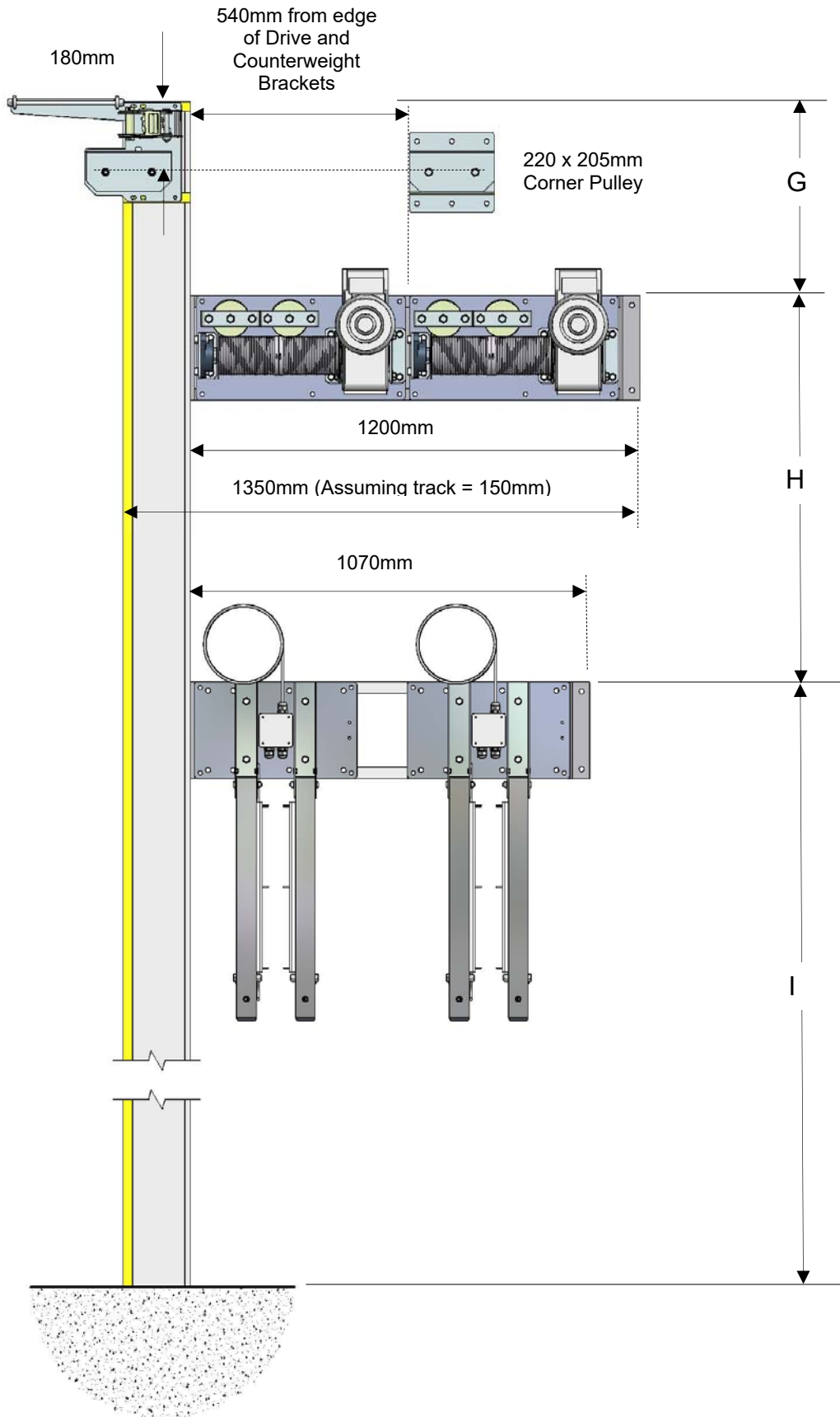

Figure 13b

15.1 Suggested design of the customer supplied brackets for adjacent drives using steel profiles is shown in Figure 14a and 14b. If alternatives are used (larger box profile, or angle) ensure the inner section indicated is clear of obstructions.

ENG

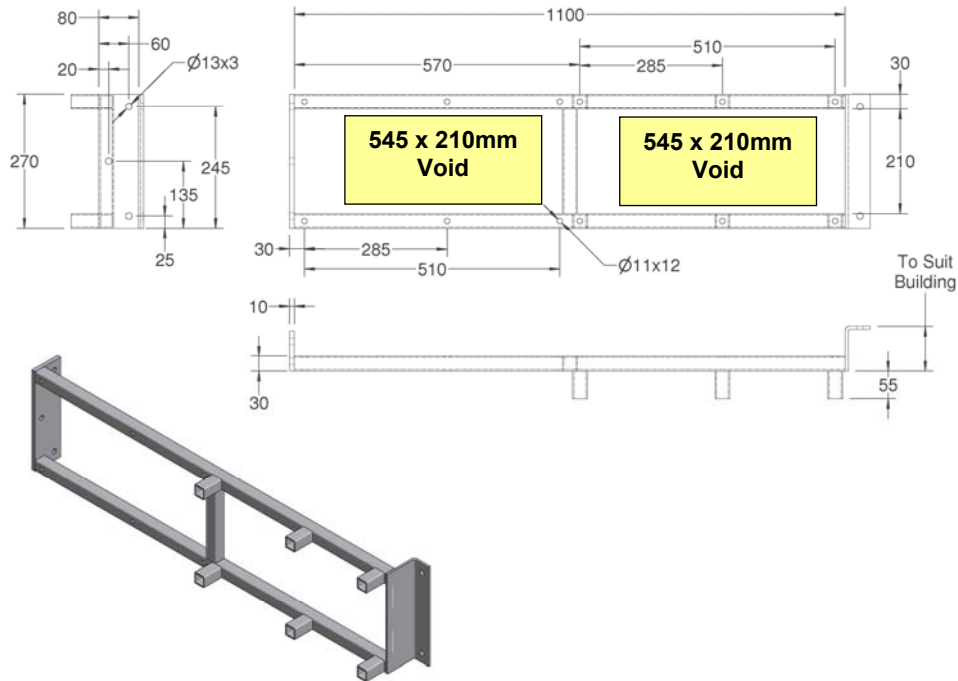

Figure 14a: Double Electric Drive Mounting Bracket

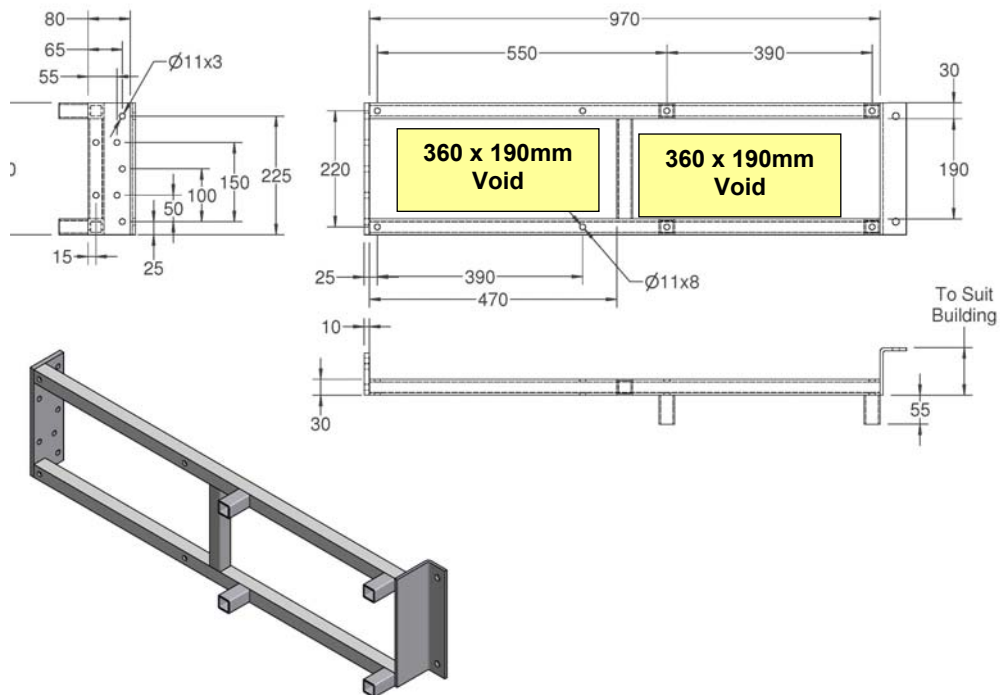

Figure 14b: Double Counterweight Mounting Bracket

MAXIDOOR® PRE-INSTALLATION

Area IX Track Extended above the Opening

16. To increase the clearance height of the door the tracking can be extended above the opening.

16.1 Extensions up to 400mm: To prevent abrasion damaging the door panel, protection needs to be placed between the building and the fabric. Head Office can supply a Galebreaker® Pelmet for this function (see Area X for details), otherwise fix soft material such as PVC strip or Rubber strip to the building.

16.2 Extensions above 400mm: In addition to panel protection as detailed above, ensure there is 300mm clearance either side of the tracking to allow the door panel to fold (Figure 15a).

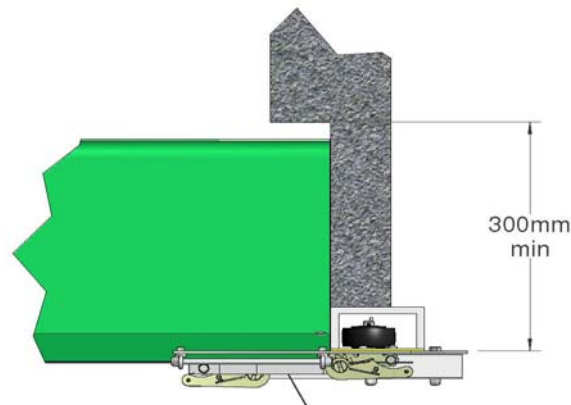

Figure 15a

16.3 Cantilever tracking extensions above the building (Figure 15b).
Contact Head Office for further advice

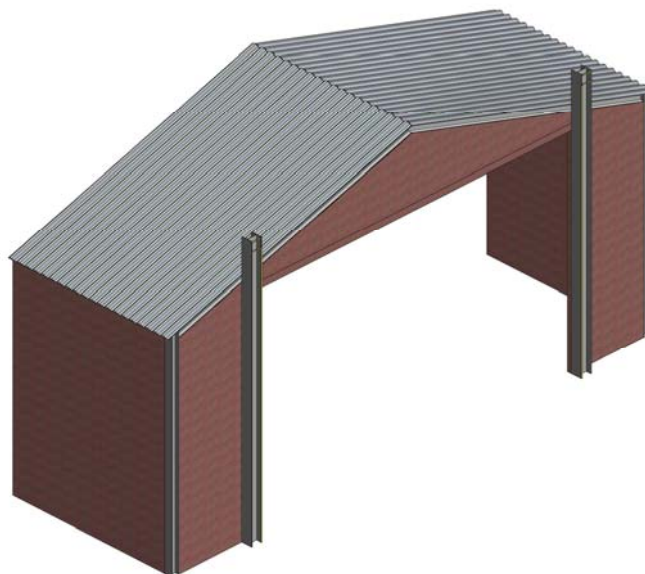

Figure 15b

ENG

17. Galebreaker® Pelmet: If required it is fixed along the full width of the opening between the top of the tracking and the bottom edge of the cladding. The Pelmet material is secured in place with a 45mm high Aluminium profile along the top and bottom (Figure 16). This profile needs to be placed on a level surface with fixings at a maximum distance of 1m, ensure the building face conforms to these requirements

ENG

When ordering please supply height P as shown on Figure 16. Note that:

- ❖ The 100mm overlap below the bottom edge of the cladding will be included during manufacture. The required dimension P is simply the vertical height from the top of the tracking to the bottom of the cladding.
- ❖ If the Pelmet material is not available in the same colour as the door, Grey will be supplied.

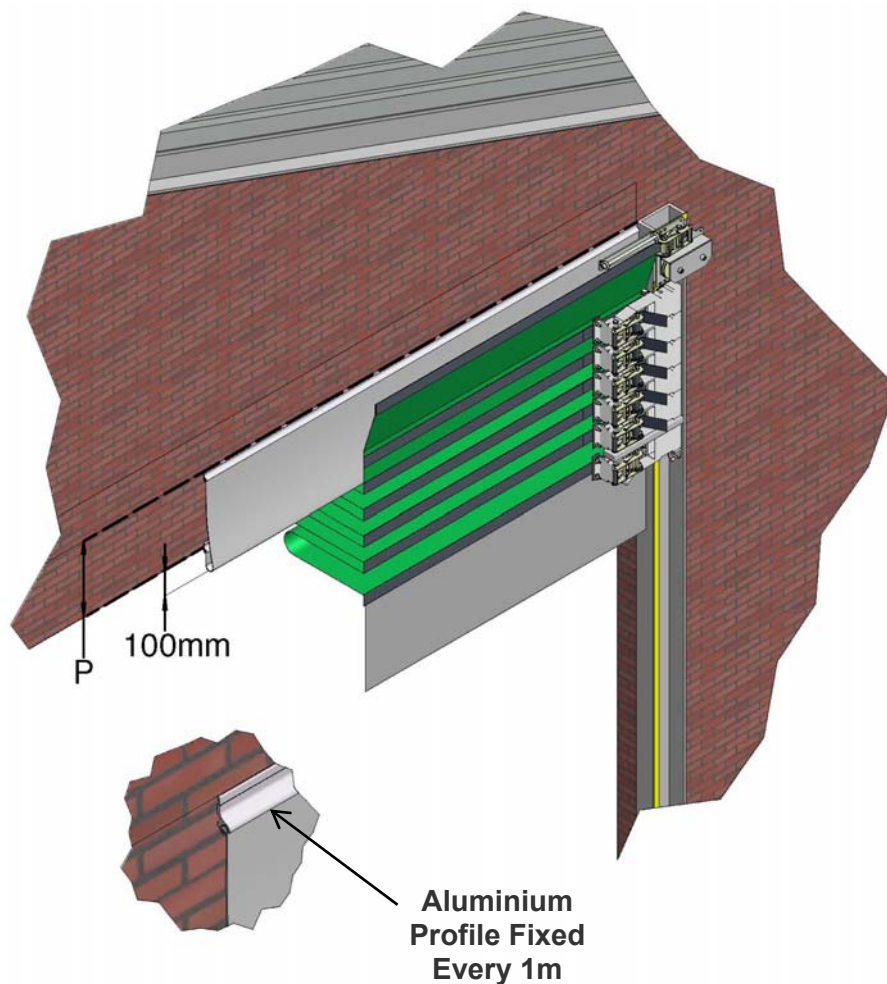

Figure 16

18. Fastenings

- ❖ Eight M8 x 30 Bolts are supplied to secure the top brackets to the tracking.
- ❖ Ten M10 x 50 Bolts are supplied to secure the Electric drive and Counterweight plates to the mounting brackets up to 30mm thick
Customer needs to supply own fastenings securing to thicker sections.

ENG

NOTE: This product has been tested to European Standard EN 12424 with a Resistance to Wind Load rating of Class 5. Tried and tested in the harshest weather conditions, a summary of our guarantee is listed below, see our website for full details:

- **Mechanical components: 100% guarantee for two years, followed by an eight year graduated guarantee.**
- **Electrical components: 100% guarantee for two years, followed by a three year graduated guarantee.**

RAIN INGRESS:

Please note that in extreme weather conditions some moisture will penetrate a mesh material.

A large grid of graph paper for taking notes, consisting of 20 columns and 30 rows of small squares.

ENG

A large grid of graph paper, consisting of 20 columns and 30 rows of small squares, intended for taking notes.

ENG



Manufacturer: Galebreaker Agri Ltd. **Tel:** +44 (0) 1531 637 900
Galebreaker House **Fax:** +44 (0) 1531 637 901
New Mills Industrial Estate
Ledbury
Herefordshire, UK
HR8 2SS

www.galebreaker.com

Designed and Manufactured in the UK by Galebreaker Agri Ltd.
Original Instructions

© Copyright Galebreaker Agri Ltd 2021. All Rights reserved

Model No: MDE/MK6/0210

Instruction Ver: 2021/01/ENG

European Authorised Representative:

Authorised Representative Service, 77 Camden Street Lower, Dublin, D02 XE80, Ireland